

RC 1:10 B74.2 TEAM KIT

1:10 Scale 4WD Electric Off Road
Competition Buggy Kit



SCALE
1:10
VEHICLE

KIT

4 WHEEL DRIVE

ELEC. POWERED

OFF ROAD

NOT INCLUDED

CLEAR BODY

#90036 RC10B74.2 TEAM KIT

1:10 Scale 4WD Electric Off Road Competition Buggy Manual



CHAMPIONS *by* DESIGN

AssociatedElectrics.com

TEAM ASSOCIATED

Introduction

Thank you for purchasing this Team Associated product. This assembly manual contains instructions and tips for building and maintaining your new vehicle. Please take a moment to read through the manual and familiarize yourself with the steps. We are continually changing and improving our designs; therefore, actual parts may appear slightly different than the illustrations. New parts will be noted on supplementary sheets located in the appropriate parts bags. Check each bag for these sheets before you start to build.

RC10B74.2 Team Kit Features

Champions by Design

As tires, motors, batteries, and tracks evolve, Team Associated adapts and improves with every iteration of the RC10. The engineers at Team Associated's Area 51 set out to extract more performance from the RC10B74 4WD buggy platform with the introduction of the RC10B74.2 and RC10B74.2D. Our goals were to reduce overall weight, lower the center of gravity, and improve jump and bump handling. The differentials were modified to improve rolling speed through turns and increase stability on landings, allowing the buggy to corner faster on high-grip carpet and clay tracks.

The RC10B74.2 and RC10B74.2D introduce molded gearboxes front and rear, which lower the center of gravity by removing weight from high points of the car. The latest 13mm big bore shock technology from Team Associated is included, taking the RC10B74.2 to the next level in jump and bump handling performance. The introduction of gull wing front suspension arms and the inclusion of the LTC gear sets for the differentials make the RC10B74.2 platform easier and more predictable to drive on any track condition.

- New lightweight molded gearboxes front and rear
- Two fixed height front gearboxes allowing 0 and +2mm diff height options
- One rear gearbox with RC10B6-style inserts allowing 0, +1, +2, and +3mm diff height options
- New 13mm big-bore threaded aluminum shocks and springs with machined shock pistons for improved bump and jump handling
- New gull wing front suspension arms and mating shock tower for lower center of gravity and better steering predictability
- LTC differential gear sets are included. That reduce binding under power, giving more predictable power delivery
- New battery hold-down system uses inserts to adjust weight bias. O-ring style battery strap with pull tabs
- New larger 3.5mm turnbuckles with updated rod end style ballcaps to increase durability and reduce bind in the suspension
- New center bulkhead fan mount that mounts the fan above the motor for better cooling performance
- New -2mm wing mounts for use with slicks and low-profile carpet tires to further lower the center of gravity
- Next-generation 2-pad high-load, high-capacity center slipper clutch with LCF pad material
- +3mm aluminum steering rack for optimized bump steer at low ride heights
- 66mm Rear CVA drive shafts and axles for more on-power traction and more predictable driving feel

Additional

Your new B74.2 Team Kit comes unassembled and requires the following items for completion (refer to catalog section for suggestions):

- | | |
|------------------------------------------------------------------|--------------------------------------------------------------------------------|
| • R/C two channel surface frequency radio system | • Battery charger
(a peak detection charger, or LiPo compatible charger) |
| • AA-size batteries for transmitter (#302 alkaline) | • 2 cell LiPo battery pack (#27382, 27383, 27384) |
| • Electronic Speed Control, ESC (#27004, 27033) | • Polycarbonate specific spray paint |
| • Steering servo (#27117, 27118, 27119) | • Cyanoacrylate glue (CA)(#1597) |
| • R/C electric motor | • Thread locking compound (#1596) |
| • Pinion gear (48P), size determined by type/turn or kV of motor | • Tires and Inserts, Fronts and Rears |
| | • Wheels w/12mm Hex
Front Wheels #92095, #92096
Rear Wheels #9695, #9696 |

Other Helpful Items

- | | | | | |
|-----------------------------------------------------------------|--------------------------------------|---------------------------------|-----------------------------|----------------|
| • Silicone Shock Fluid (Refer to catalog for complete listings) | • FT Body Scissors (#1737) | • FT Body Reamer (#1499) | • Shock Pliers | • Wire Cutters |
| • FT Hex/Nut Wrenches (#1519) | • FT Universal Tire Balancer (#1498) | • Needle Nose Pliers | • FT Ballcup Wrench (#1579) | • Hobby Knife |
| • FT Dual Turnbuckle Wrench (#1114) | • Green Slime shock lube (#1105) | • Calipers or a Precision Ruler | • Soldering Iron | |



















Associated Electrics, Inc.
21062 Bake Parkway.
Lake Forest, CA 92630



Customer Service
Tel: 949.544.7500
Fax: 949.544.7501

Hardware - 1:1 Scale View









Button Head (bhcs)

	2x4mm (31510)
	2.5x5mm (31519)
	2.5x6mm (31520)
	2.5x8mm (31521)
	2.5x10mm (31522)
	3x4mm (91158)
	3x5mm (31530)
	3x6mm (31531)
	3x8mm (31532)
	3x10mm (25211)
	3x12mm (89202)
	3x14mm (25187)
	3x16mm (89203)
	3x18mm (2308)
	3x20mm (25188)
	3x22mm (25189)
	3x24mm (89204)
	3x30mm (91478)

Set Screws

	3x2.5mm (31500)
	3x3mm (25225)
	3x10mm (4671)

Flat Head (fhcs)

	2x3mm (91743)
	3x6mm (31541)
	3x8mm (25201)
	3x10mm (25202)
	3x12mm (25203)
	3x14mm (89208)
	3x16mm (25204)
	3x18mm (89209)





Cap Head (shcs)

	1.6 x 5mm (91611)
-----------------------------------------------------------------------------------	-------------------







LP Socket Head (lp shcs)

	3x6mm (41089)
	3x22mm (41095)









Shims and Washers

	5.5x0.5mm (31381)
	5.5x1.0mm (31382)
	5.5x2.0mm (31383)
	3x8mm Washer (89218)









Ball Bearings

	4x7x2.5mm (31732)
	5x8x2.5mm (31400)
	5x10x4mm (91560)
	5x10x4mm flanged (92324)
	5x12x4 (91567)
	10x15x4 (91563)

Ballstuds

	Silver 5mm long (31283)
	Silver 8mm long (31284)
	HD 6mm (91047)
	Ti HD 6mm (91751)
	HD 8mm (91048)
	Ti HD 8mm (91752)
	HD 10mm (91049)
	Ti HD 10mm (91753)

Nuts (lock/plain)

	M3 Nut (91477)
	M3 Alum. Locknut, Blue (31550)
	M3 Locknut, Black (25215)
	M3 Locknut w/Flange (25612)
	FT 3mm Locknuts, Blue(25392)
	M4 Locknuts: Serrated Steel LP (91150)
	Serrated Steel (Silver) (91826)
	FT Aluminum (Blue) (31551)
	Serrated Aluminum (Black) (91738)

Notes:

:: Table of Contents

1.....	Cover	13.....	Rear Hubs Build Bag 8
2.....	Introduction	13.....	Turnbuckles Build Bag 9
3.....	1:1 Hardware “Fold Out”	15.....	Center Slipper Build Bag 10
4.....	Table of Contents	16.....	Shocks Build Bag 11
5.....	Chassis Build Bag 1	17.....	Anti-Roll Bars Build Bag 12
5.....	Suspension Arms Build Bag 2	19.....	Electronics / Body Build Bag 13
6.....	Front / Rear Gear Differentials Build Bag 3	22.....	Tuning Tips
7.....	Front / Rear Gearbox Build Bag 4	24.....	Catalog
8.....	Bulkhead / Shock Tower Build Bag 5	32.....	Setup Sheet “Kit Setup”
10.....	Steering Build Bag 6	33.....	Setup Sheet “Blank”
12.....	Caster Blocks Build Bag 7	34.....	Back Cover

:: Notes



This symbol indicates a special note or instruction in the manual.



This symbol indicates a Racers Tip.



There is a 1:1 hardware foldout page in the front of the manual. To check the size of a part, line up your hardware with the correct drawing until you find the exact size. Each part in the foldout has a number assigned to it for ordering replacement parts.

Associated Electrics, Inc.
21062 Bake Parkway.
Lake Forest, CA 92630



Customer Service
Tel: 949.544.7500
Fax: 949.544.7501

:: Bag 1 - Step 1

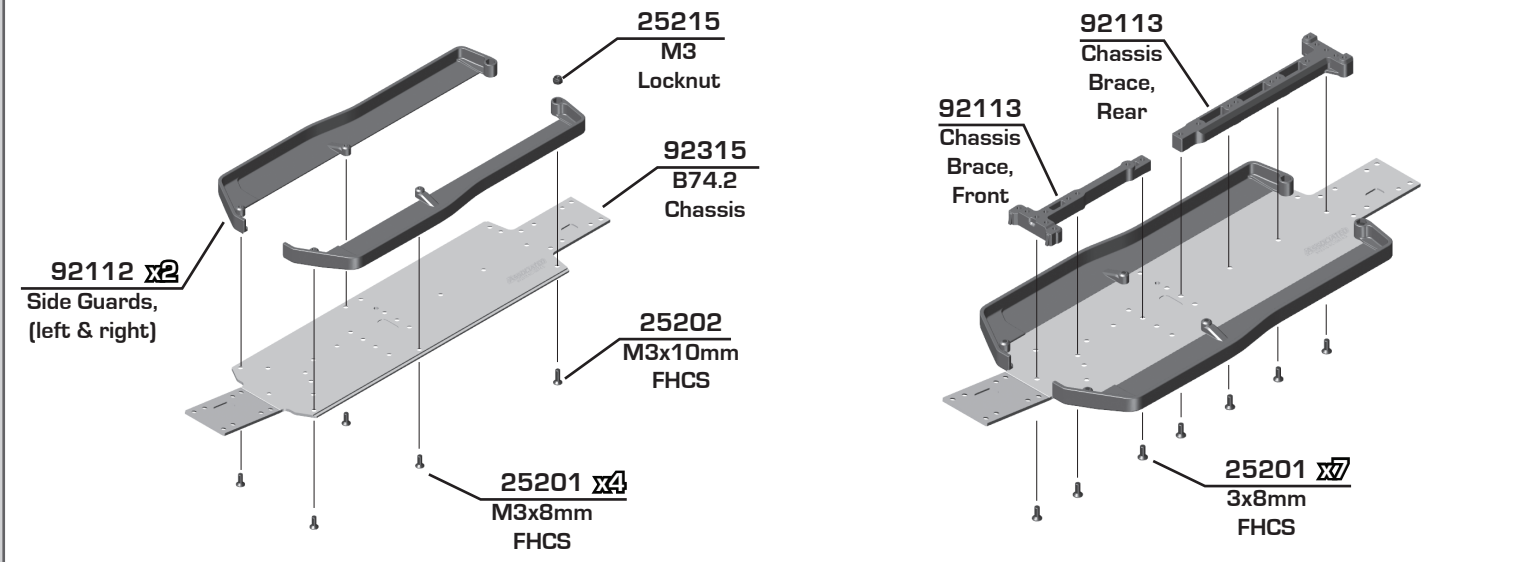

:: Bag 1 - Step 2

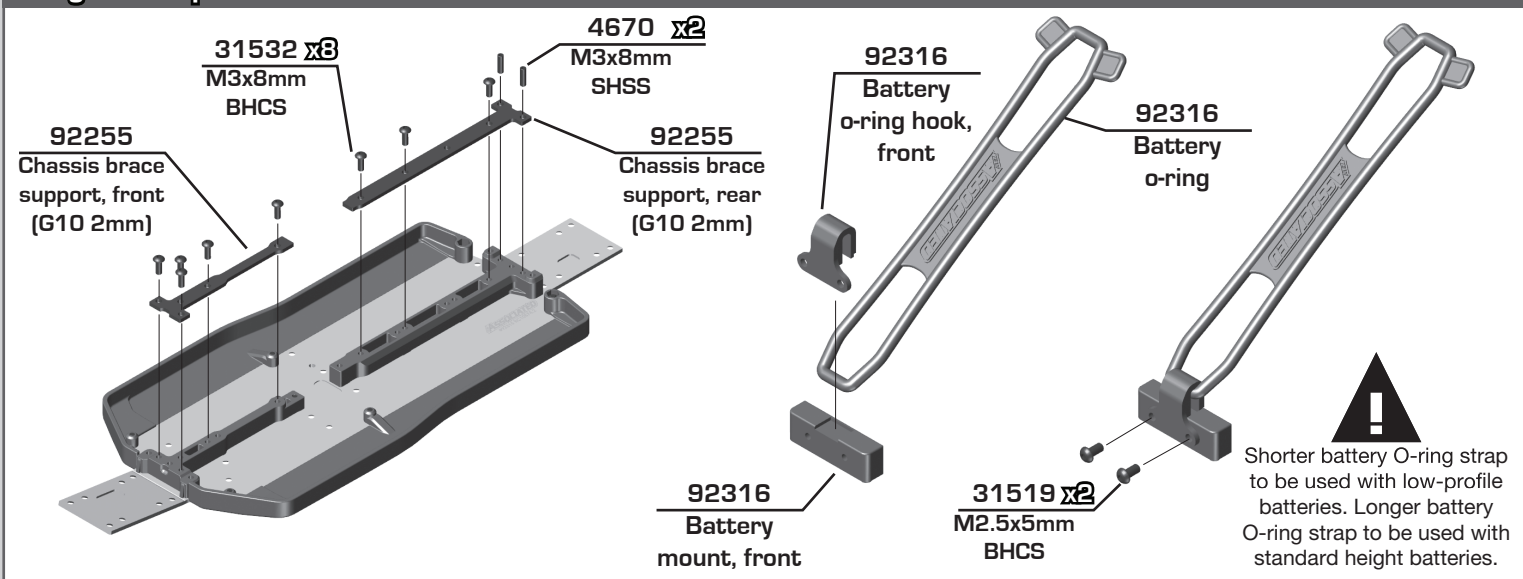

:: Bag 1 - Step 3

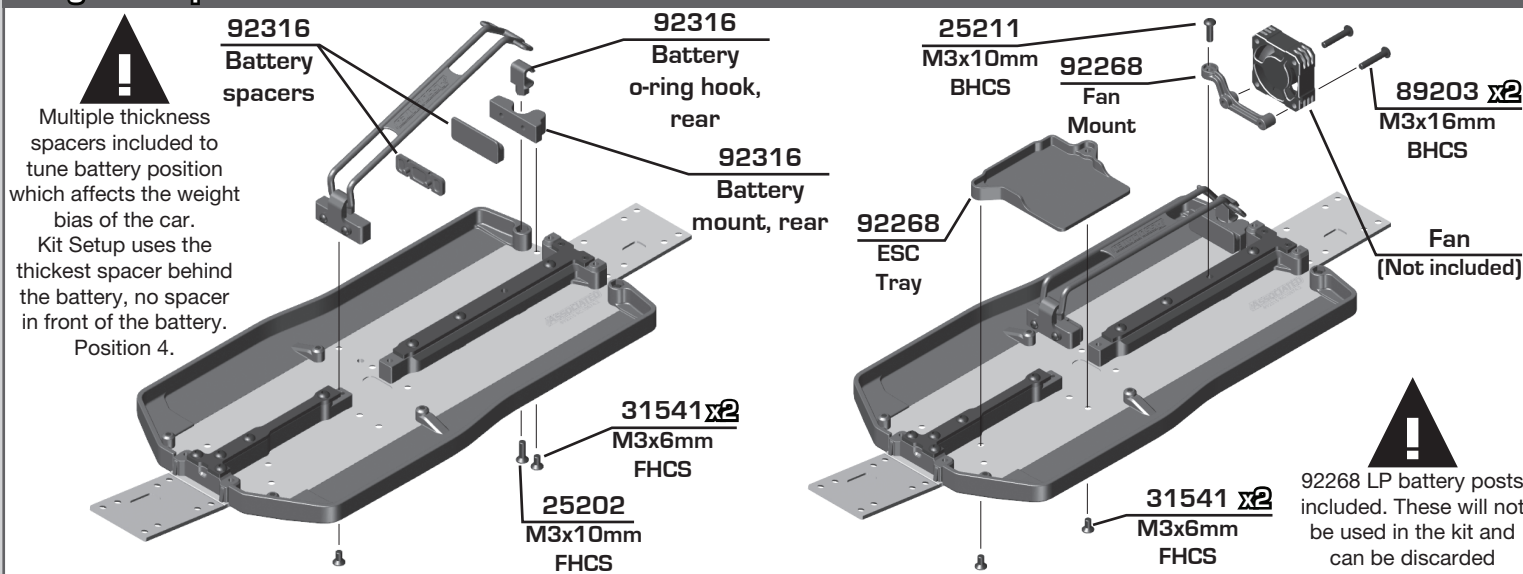

:: Bag 2 - Step 1

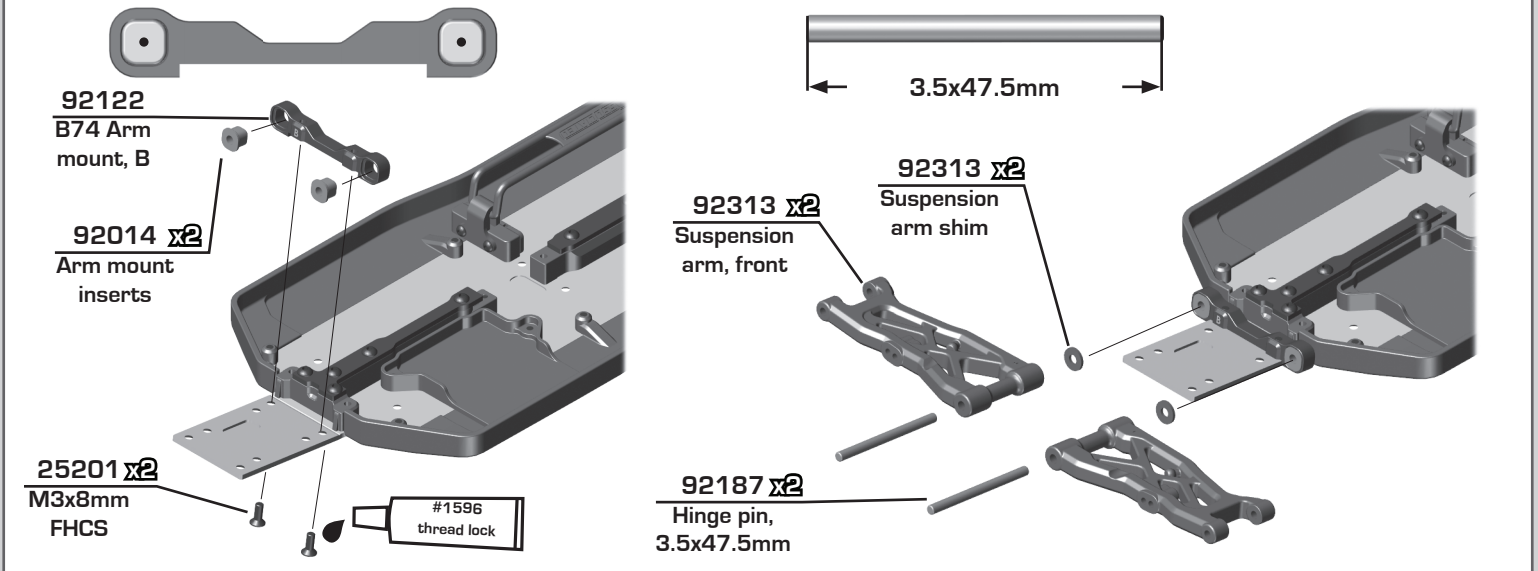

:: Bag 2 - Step 2

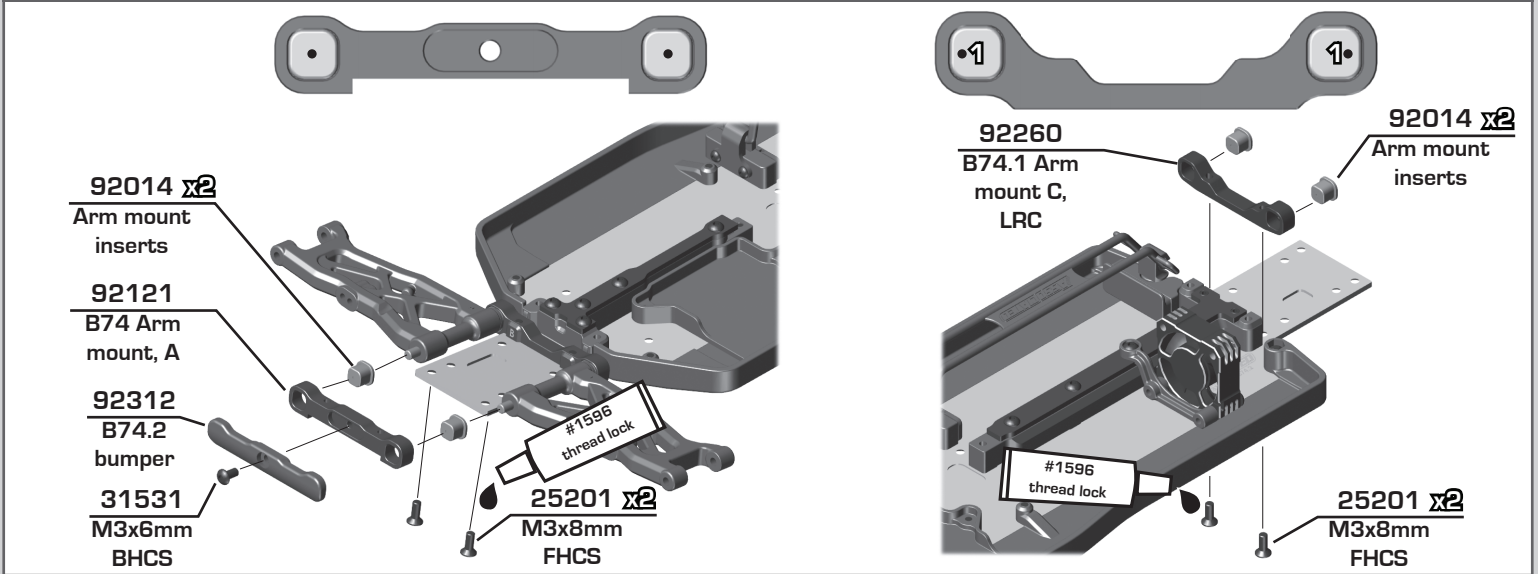

:: Bag 2 - Step 3

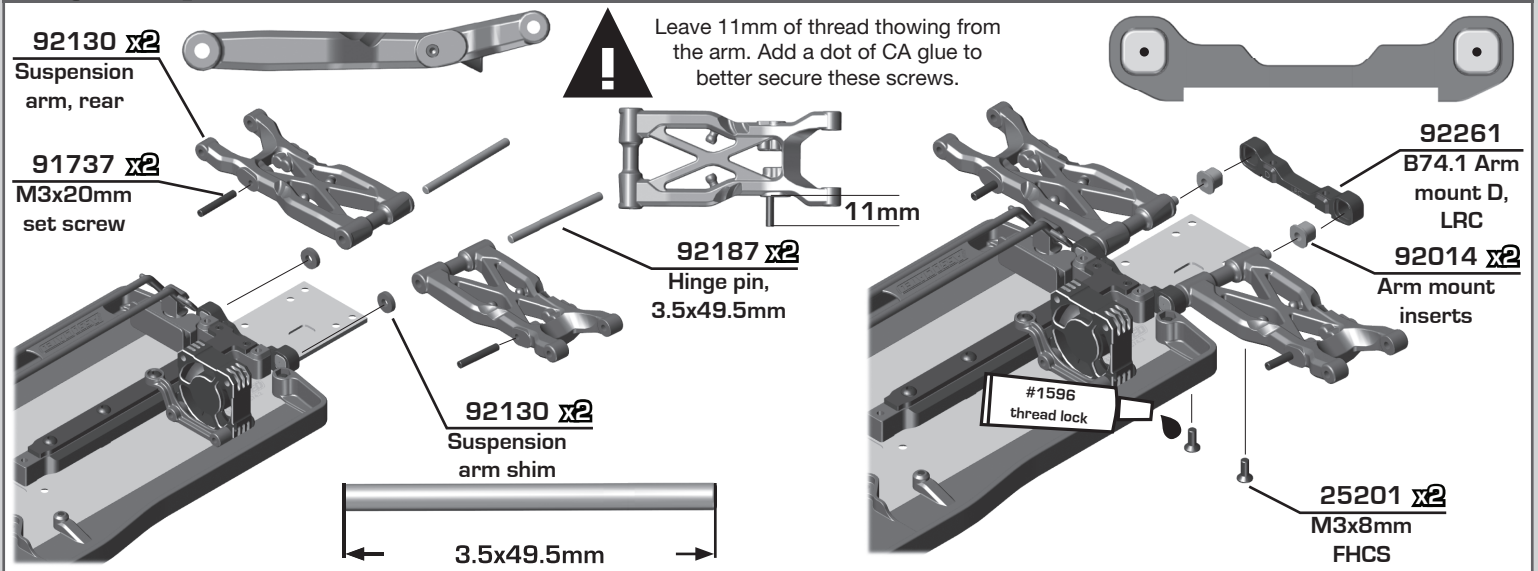

:: Bag 3 - Step 1

Build x2 (1 front, 1 rear)

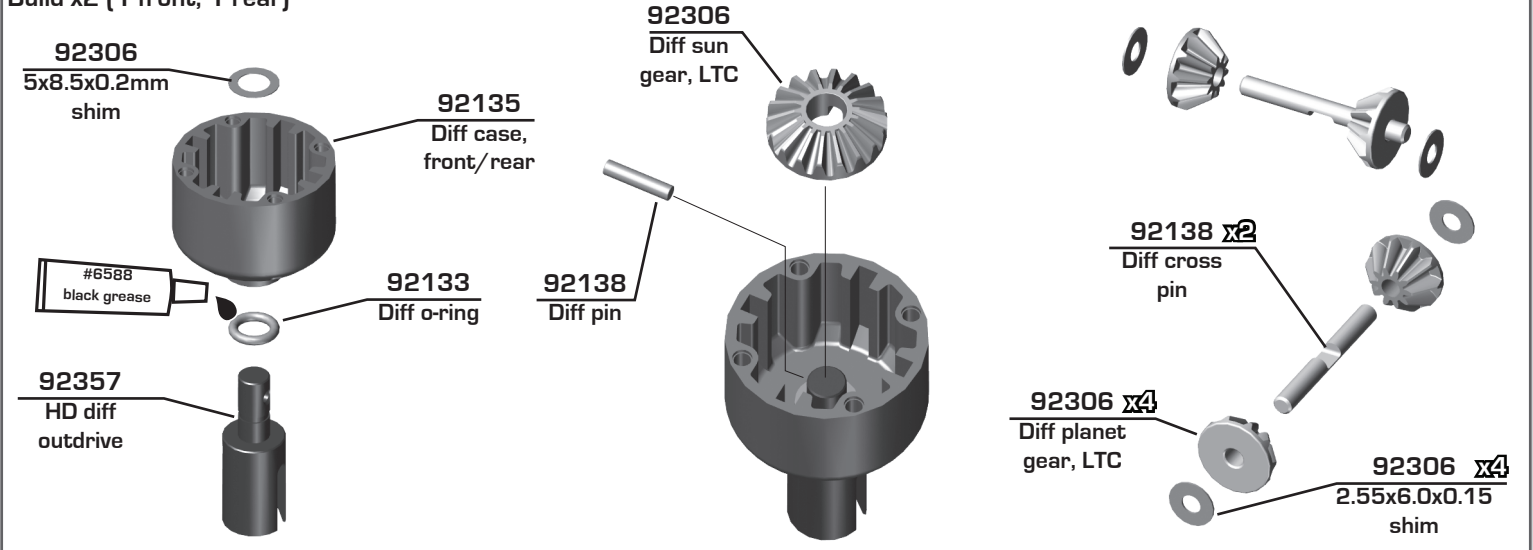

:: Bag 3 - Step 2

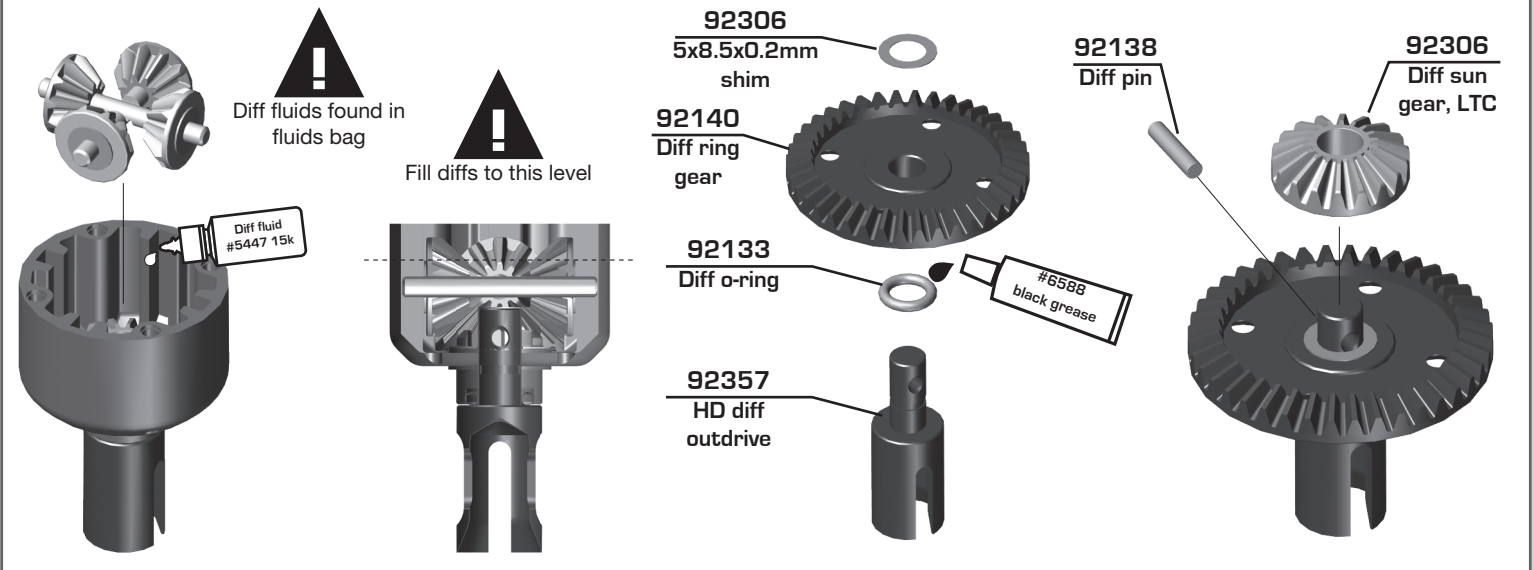

:: Bag 3 - Step 3



It is important that the correct amount of fluid is added to the diff. Too much fluid may cause the diff to fail. Fill diffs to the reference line shown above. A more accurate method is to use a digital scale (AE#1522) to make sure the correct amount of fluid is added on the first build, and subsequent rebuilds. The entire diff assembly should weigh **45.25g** when built. Start by placing the ring gear assembly, screws, and cup assembly (without fluid) onto the scale.

Then slowly add fluid to the cup assembly until the overall mass is **45.25g**.

B74 Diff Weights (minus bearings)	Weight (grams)	
	Metal	Plastic
F/R Differential	45.25	36
Center Differential	43.75	34.5

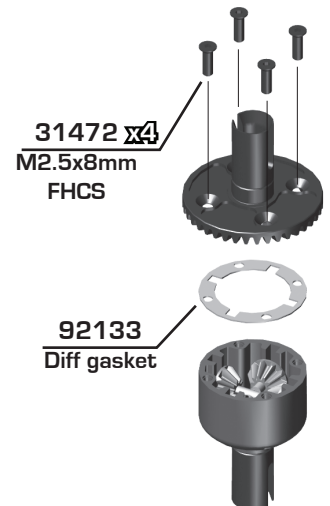
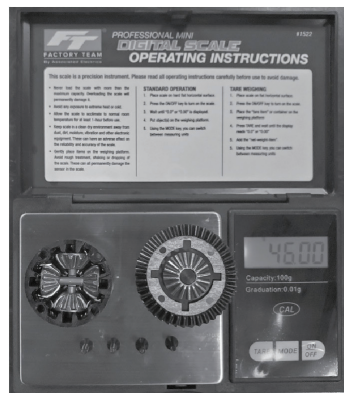

Build x2 (1 front, 1 rear)

:: Bag 4 - Step 1

Build front gearbox

92324 x2
M5x10x4
flanged bearing

92319
Diff pinion
gear shim,
M5x6.5x1mm

92142
Diff pinion
gear

92309
B74.2 front
gearbox,
inboard,
#2

91563 x2
M10x15x4
bearing

92139 x2
Diff shim

0 & 2 are included in kit.
"2" gearbox for front,
"0" height is optional.

Start by shimming the diff with one shim on either side of the diff. If the diff is tight when inserted into the gearbox, remove one shim from the ring gear side and add it to the diff case side.

:: Bag 4 - Step 2

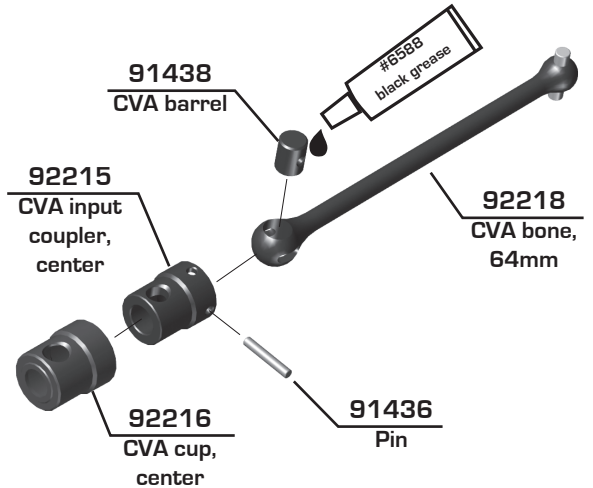
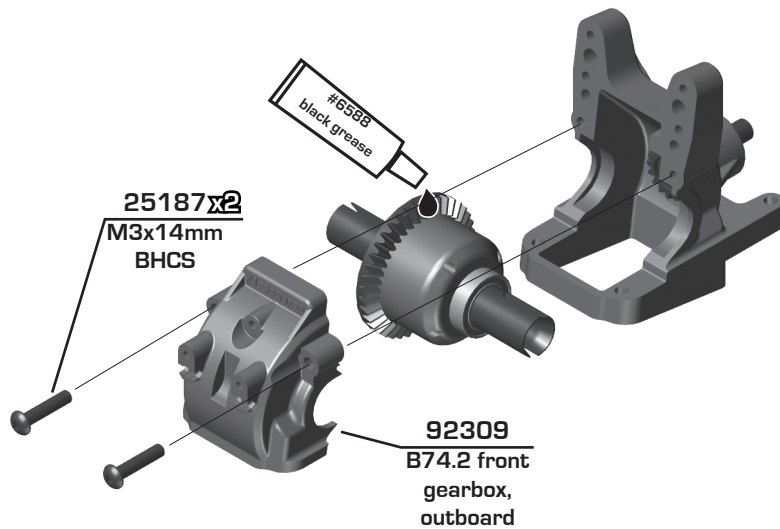

:: Bag 4 - Step 3

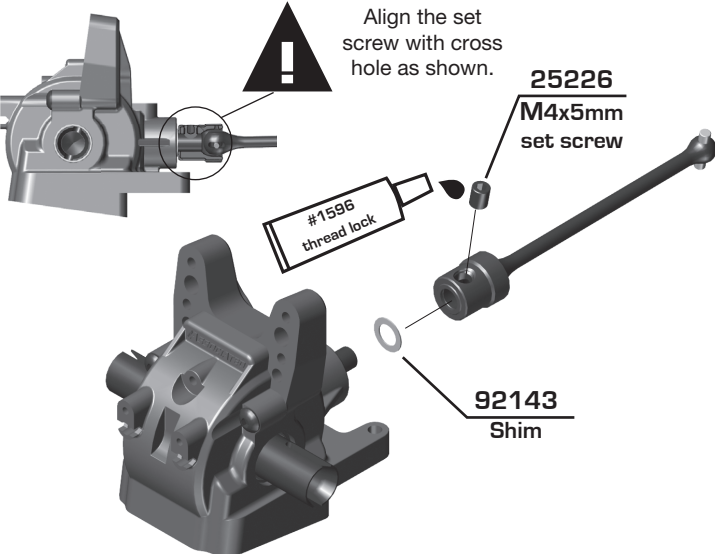

Build rear gearbox

92324 x2
M5x10x4
flanged bearing

92311 x2
B74.2 rear
gearbox pinion
height insert,
1 and 2

92310
B74.2 rear
gearbox,
bottom

92142
Diff pinion
gear

92319
Diff pinion
gear shim,
M5x6.5x1mm

Number shown on top of the insert after insertion should match the diff height desired. Kit setup: "2"

:: Bag 4 - Step 4

Start by shimming the diff with one shim on either side of the diff. If the diff is tight when inserted into the gearbox, remove one shim from the ring gear side and add it to the diff case side.

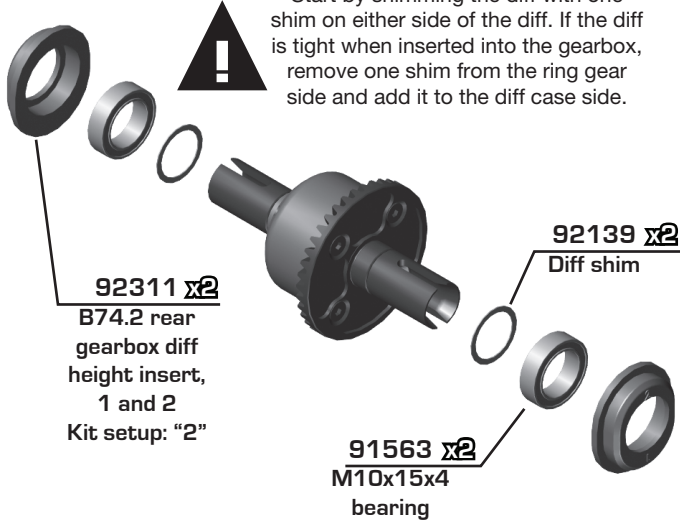

92310
B74.2 rear gearbox, top

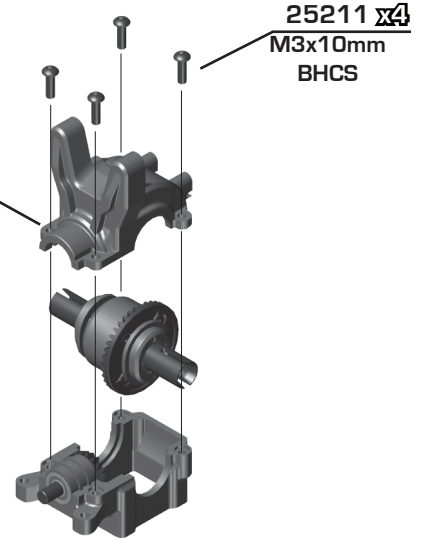

Take extra care not to strip these screw holes out. Stripping the plastic will result in premature failure.

:: Bag 4 - Step 5

Align the set screw with cross hole as shown.

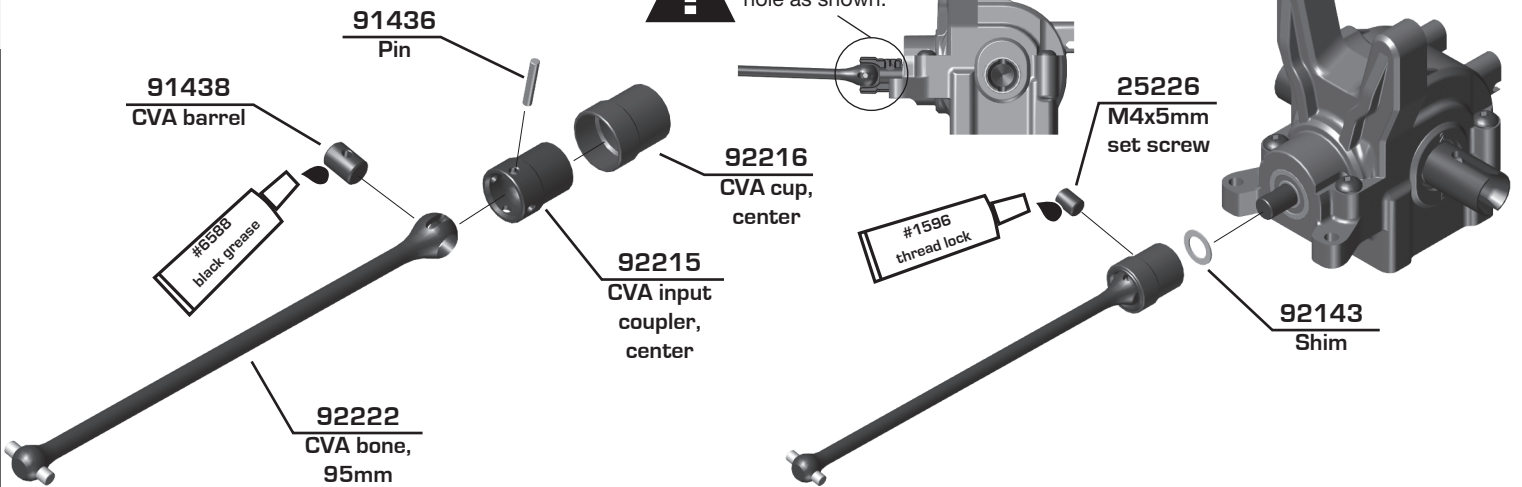

:: Bag 4 - Step 6

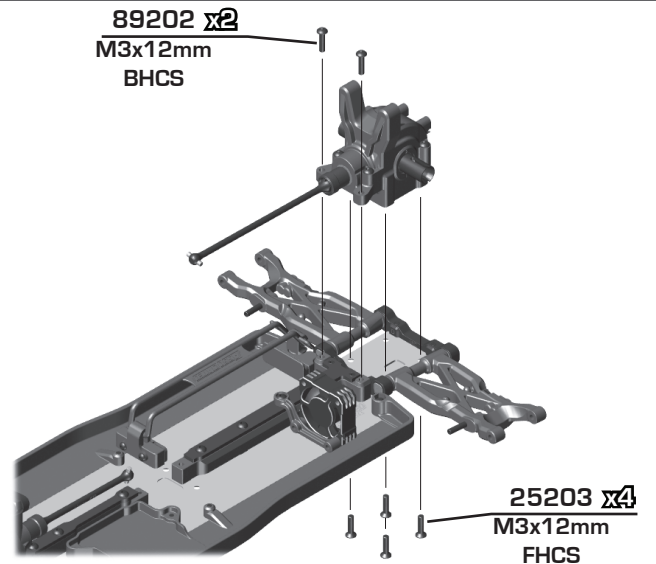
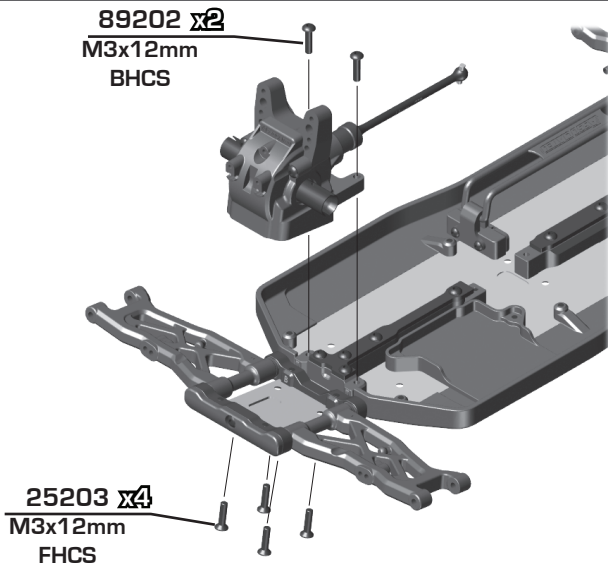

:: Bag 5 - Step 1

Build front shock tower

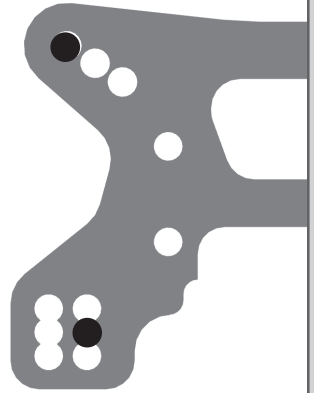
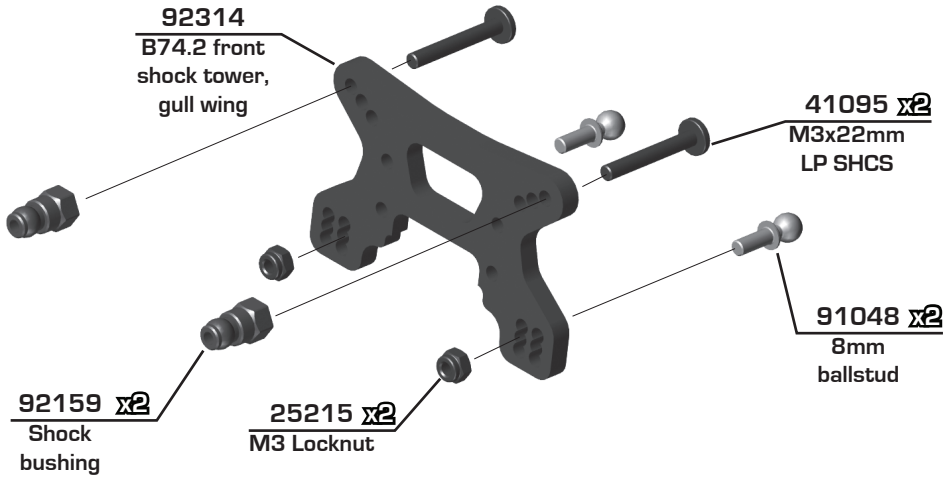

Tuning Tip: Use the shorter location for less steering and more stable front end, although this might slow cornering speed.

:: Bag 5 - Step 2

Build rear shock tower

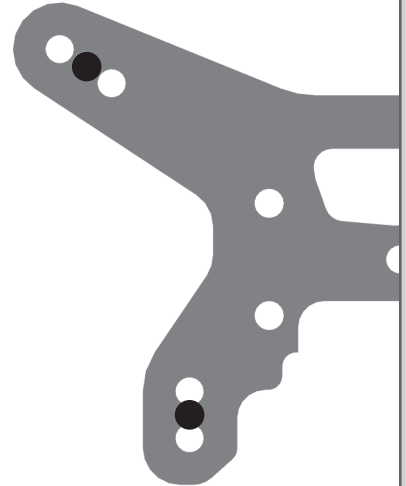
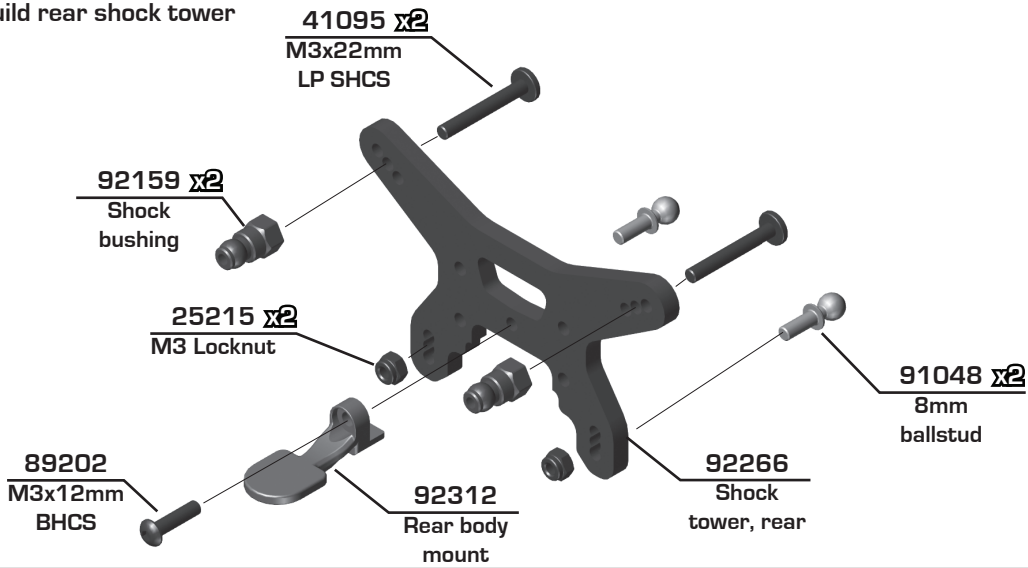

:: Bag 5 - Step 3

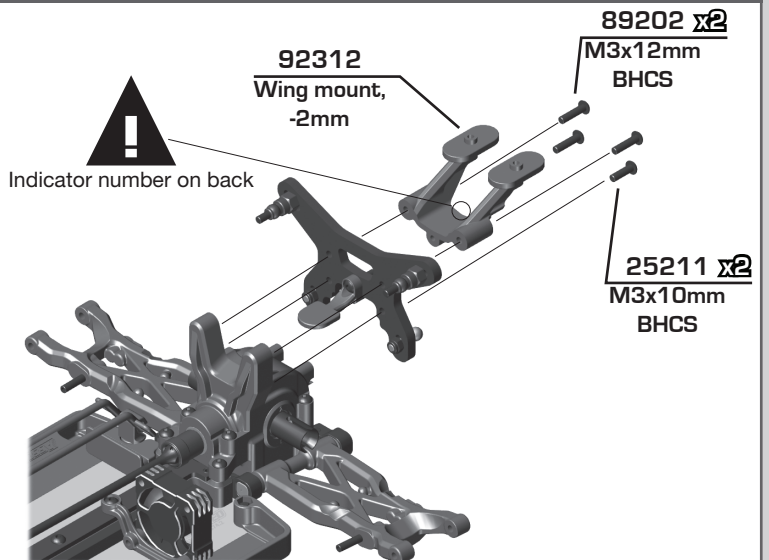
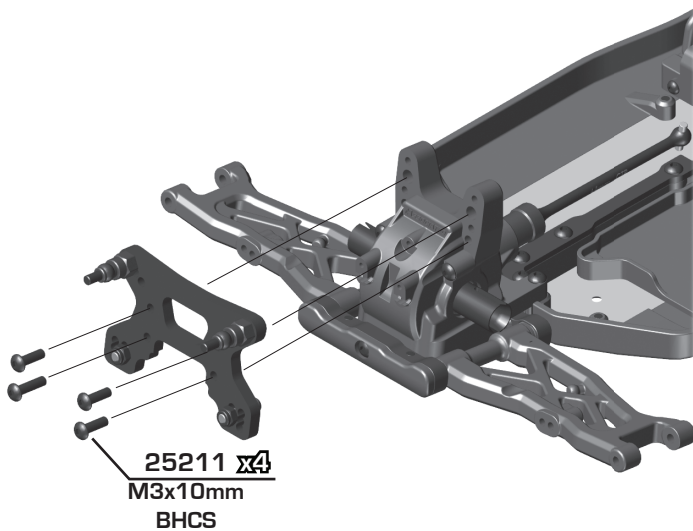

:: Bag 6 - Step 1

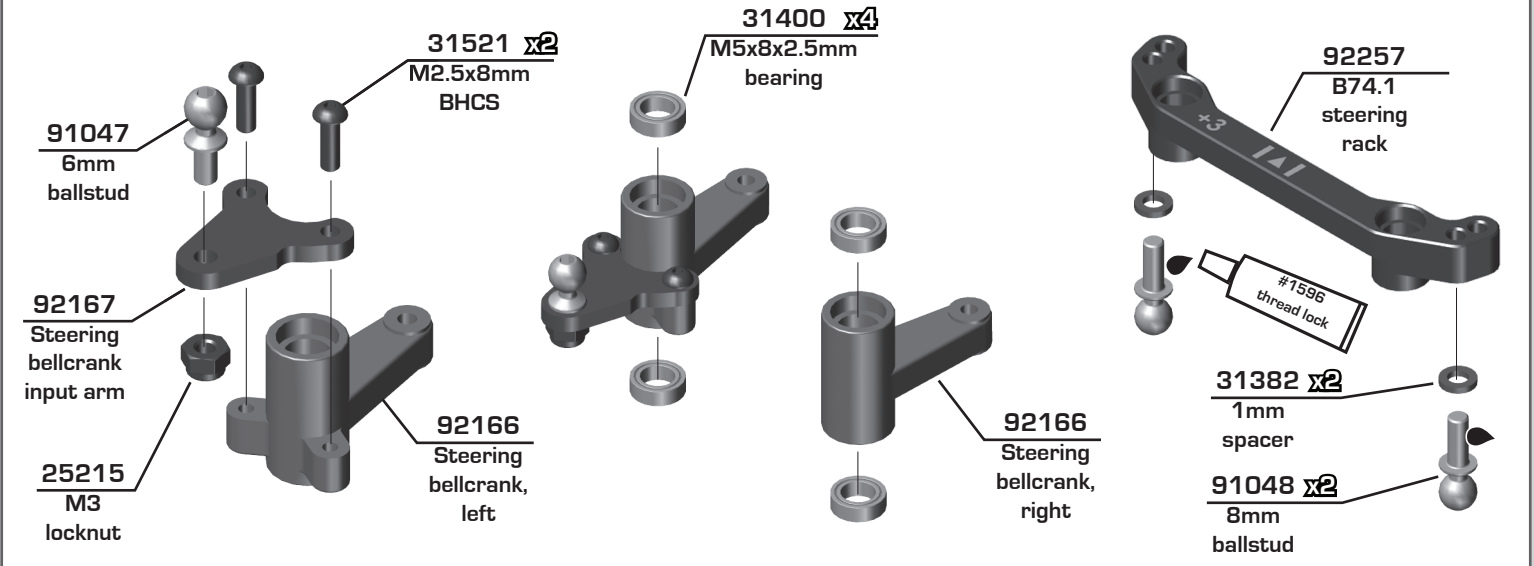

:: Bag 6 - Step 2

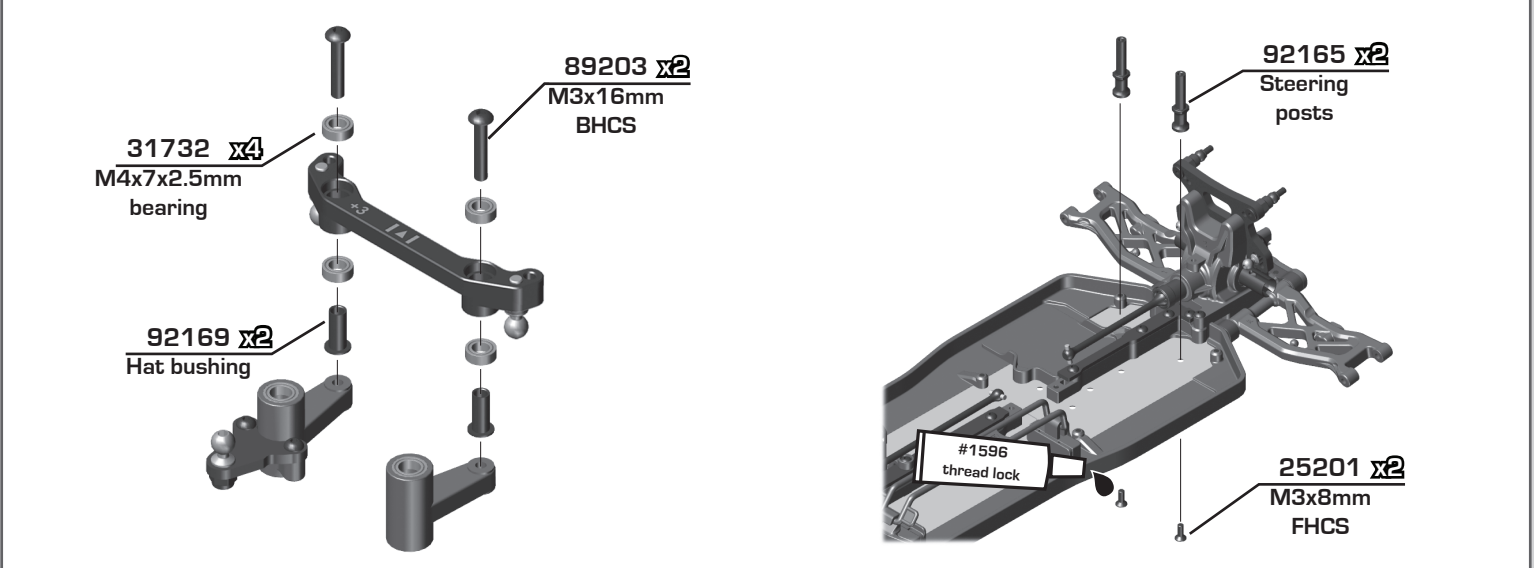

:: Bag 6 - Step 3

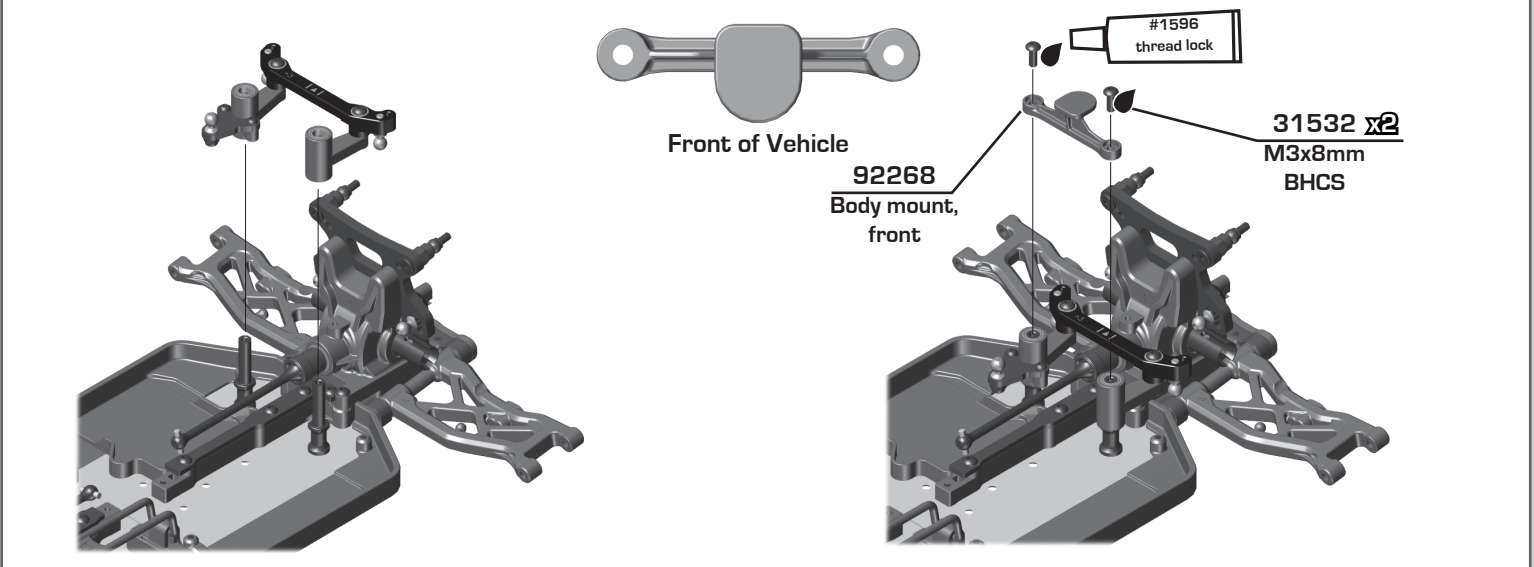

:: Bag 7 - Step 1

Build x2
(1 left side, 1 right side)

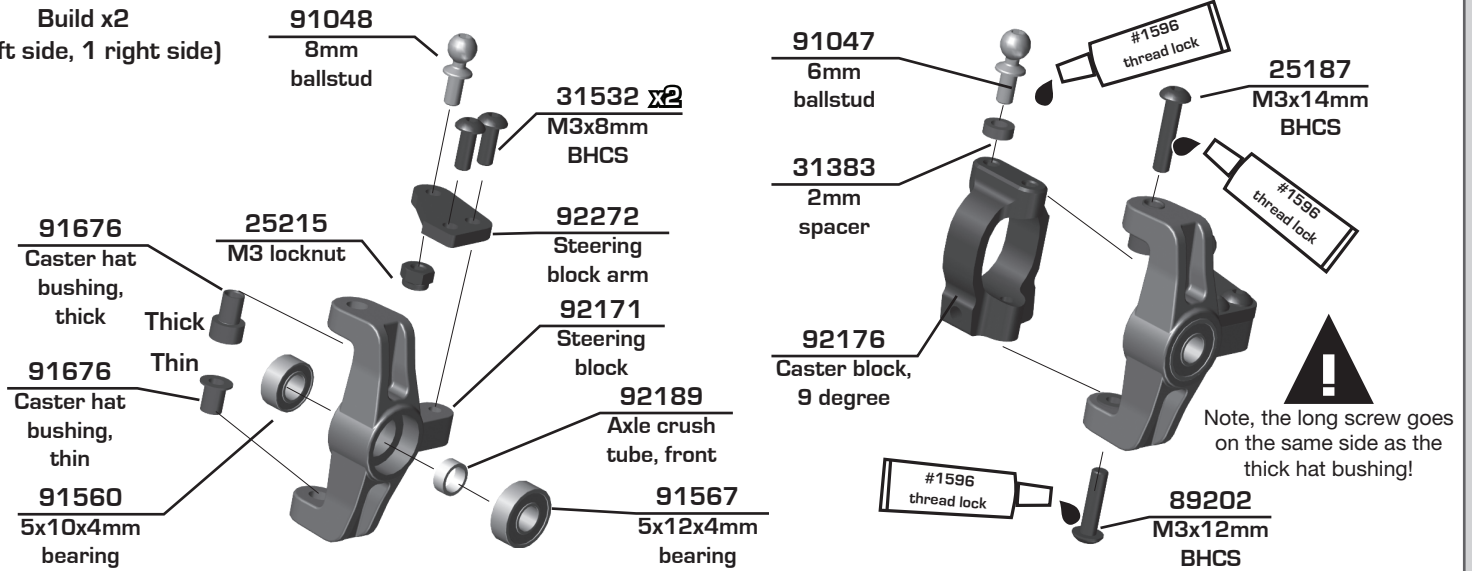

:: Bag 7 - Step 2

Build x2
(1 left side, 1 right side)

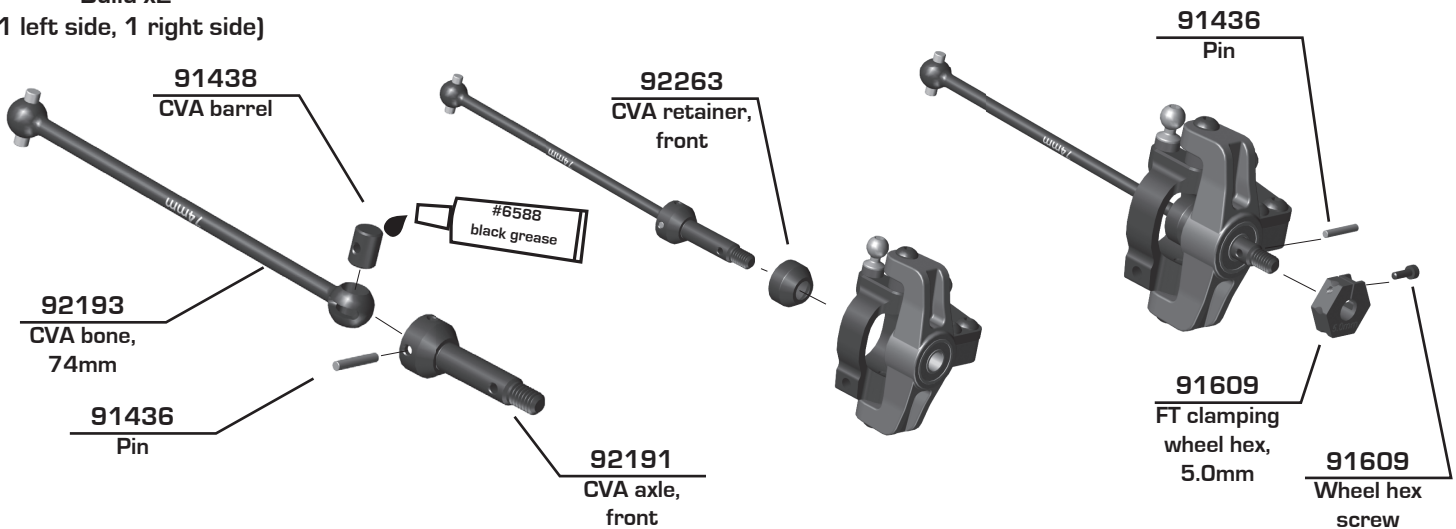

:: Bag 7 - Step 3

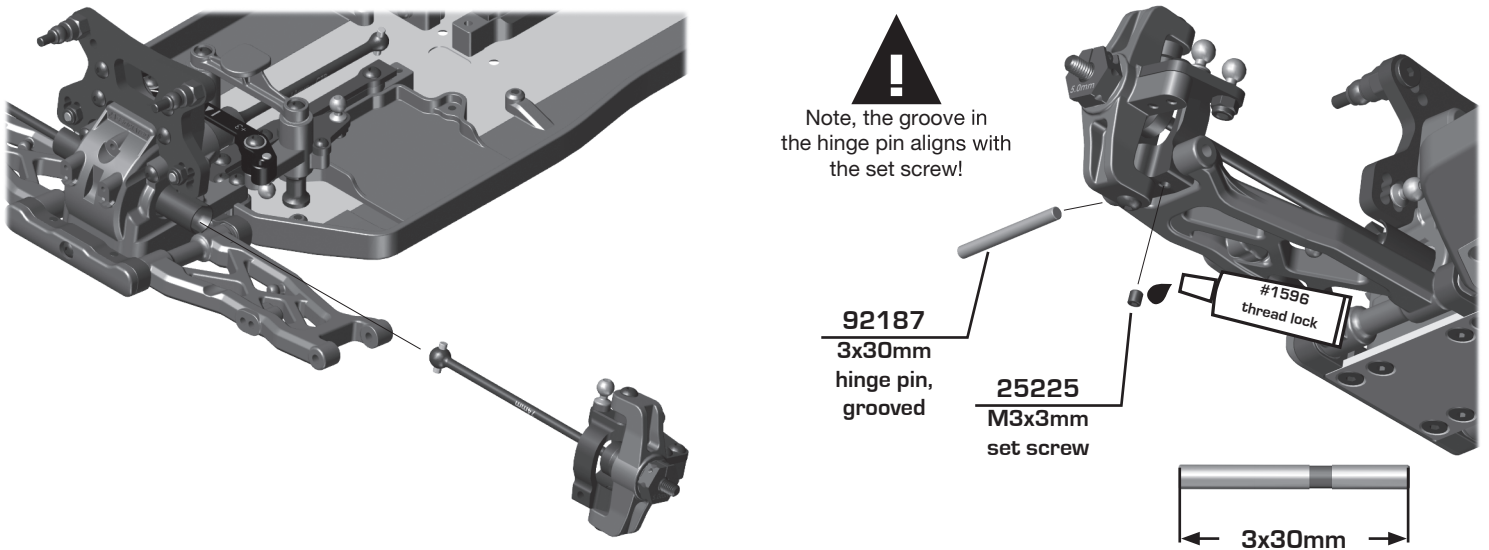

Bag 8 - Step 1

91047 6mm ballstud

#1596 thread lock

92180 Rear hub link mount

31383 2mm spacer

92267 Rear hub and insert (+2mm)

31382 x2 1mm spacer

89202 x2 M3x12mm BHCS

Rear Axle Height		
	↓ 0 3 ↑	+3mm
	↓ 1 2 ↑	+2mm
	↑ 1 2 ↓	+1mm
	↑ 0 3 ↓	+0mm

Bag 8 - Step 2

92299 CVA bone, 66mm

91438 CVA barrel

#6588 black grease

92207 CVA axle 66mm, rear

91436 Pin

91563 10x15x4mm bearing

91567 5x12x4mm bearing

91436 Pin

71034 FT clamping wheel hex, 6.0mm

91609 Wheel hex screw

Build x2 (1 left side, 1 right side)

Clamping hex found in Tuning Parts Bag

Bag 8 - Step 3

Build x2 (1 left side, 1 right side)

92267 x2 Rear hub spacer

92188 Rear hub hinge pin

25215 M3 locknut

Do not overtighten after threads stop

Bag 9 - Step 1

It is important that the turnbuckle eyelets move freely once snapped on to the ballstud. If the fit is too tight, the car handling will be inconsistent. To check, grab turnbuckle eyelet with fingers and rotate the cup. If there is resistance, lightly squeeze ball cup with needle nose pliers as shown and test again. It is important that the ball cup be snapped onto the ballstud before squeezing with needle nose pliers. Be sure to check and adjust the fit for each ball cup that is installed.

:: Bag 9 - Step 2



92308 x2
Ballcup,
straight

92335
3.5x42mm
turnbuckle

! Orient the notch to the left throughout the car. It indicates which end has the left hand threads!

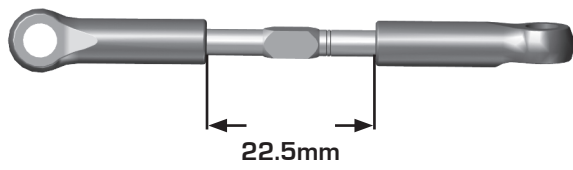

Build x2 (1 left side, 1 right side)

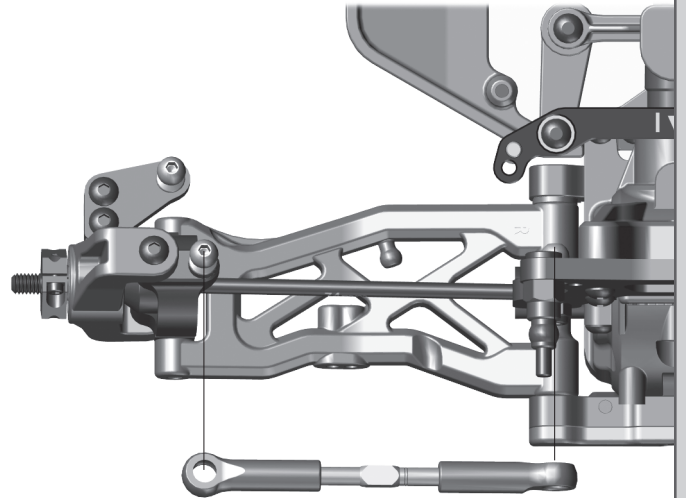

:: Bag 9 - Step 3

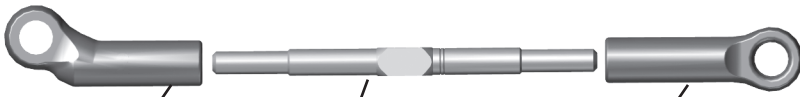

92308
Ballcup,
Offset

92335
3.5x42mm
turnbuckle

92308
Ballcup,
straight

! Orient the notch to the left throughout the car. It indicates which end has the left hand threads!

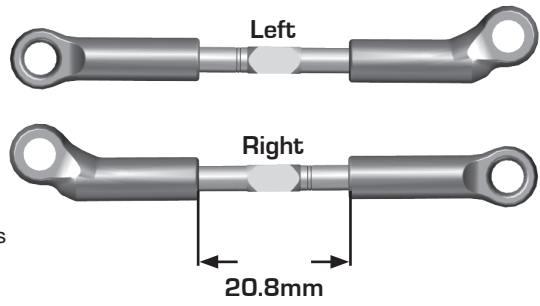

! There is two offset ballcups labeled "1" and "2". The ballcup labeled "1" goes on the left side of the car.

Build x2 (1 left side, 1 right side)

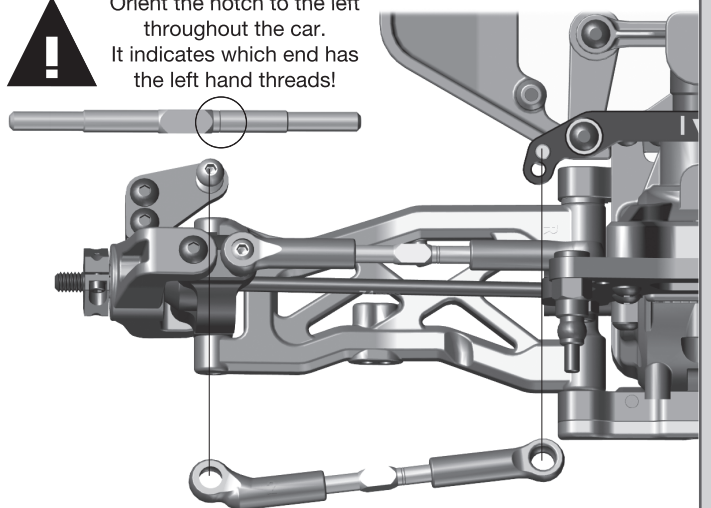

:: Bag 9 - Step 4



92308 x2
Ballcup,
straight

92336
3.5x45mm
turnbuckle

! Orient the notch to the left throughout the car. It indicates which end has the left hand threads!

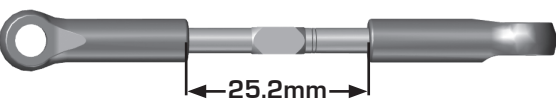

Build x2 (1 left side, 1 right side)



92308 x2
Ballcup,
straight

92333
3.5x35mm
turnbuckle

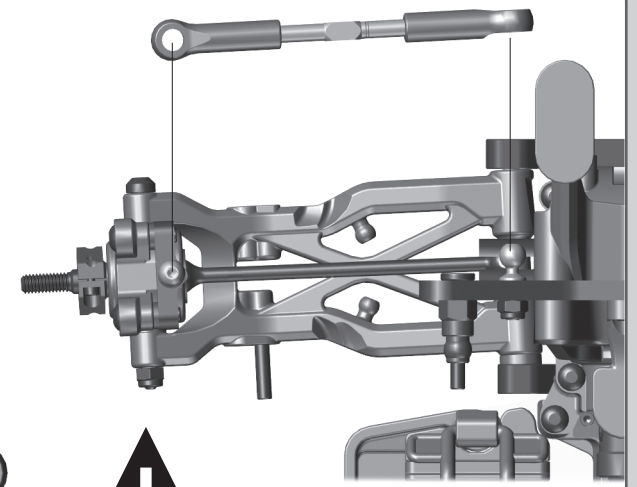
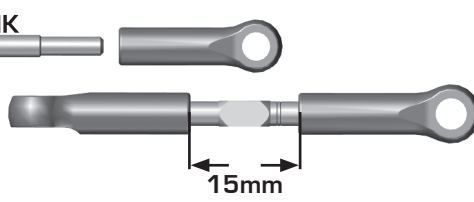

! Set this aside for installation when you install the servo!

:: Bag 10 - Step 1



Screw set screw in 1/2 of the depth, use it to lock nut into final setting.

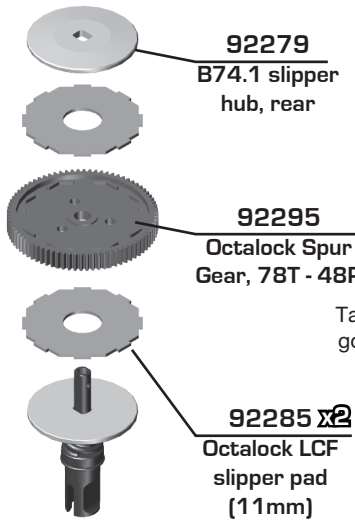
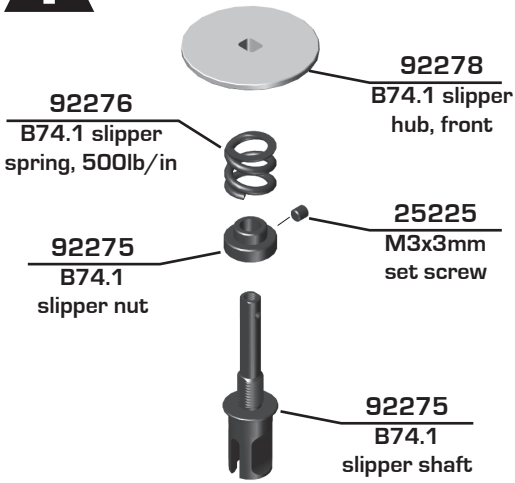

Tall side of spur gear goes towards spring

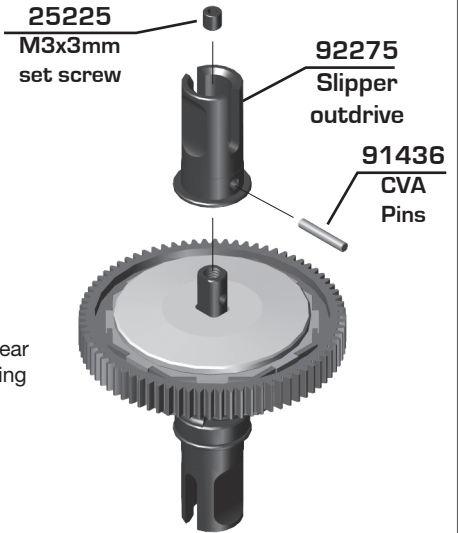

:: Bag 10 - Step 2



Range of adjustment is 2.1mm to 3.3mm gap. Start at 2.1mm

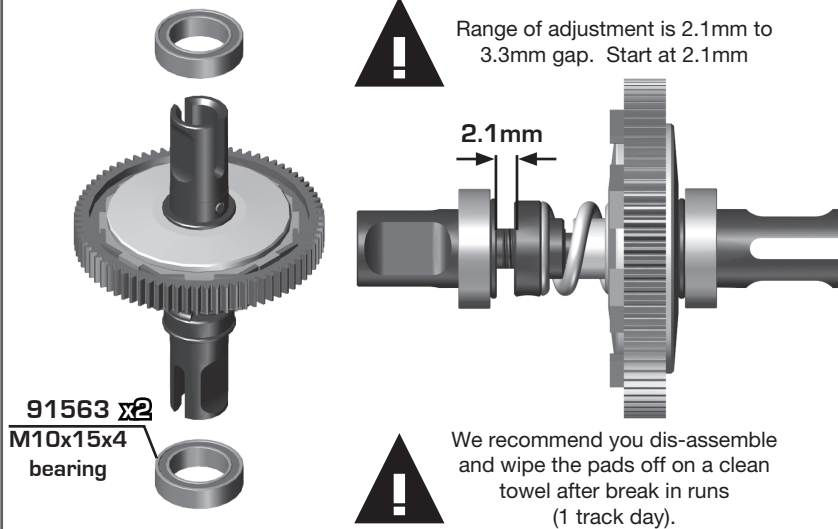

We recommend you dis-assemble and wipe the pads off on a clean towel after break in runs (1 track day).

92235 Motor mount

92237 Center bulkhead

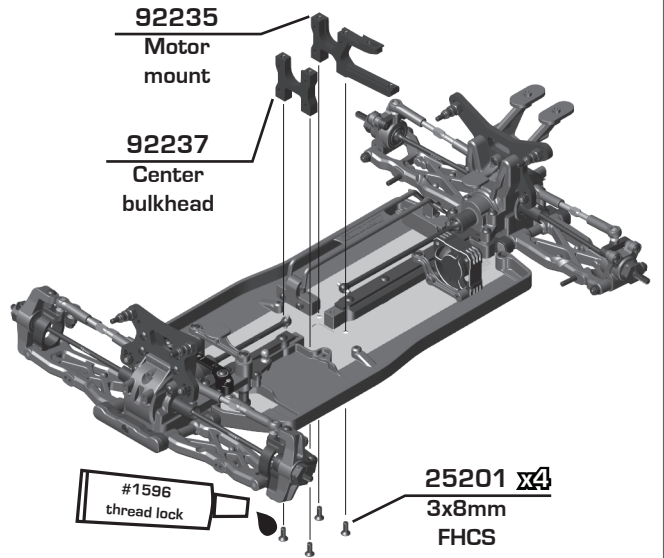

:: Bag 10 - Step 3

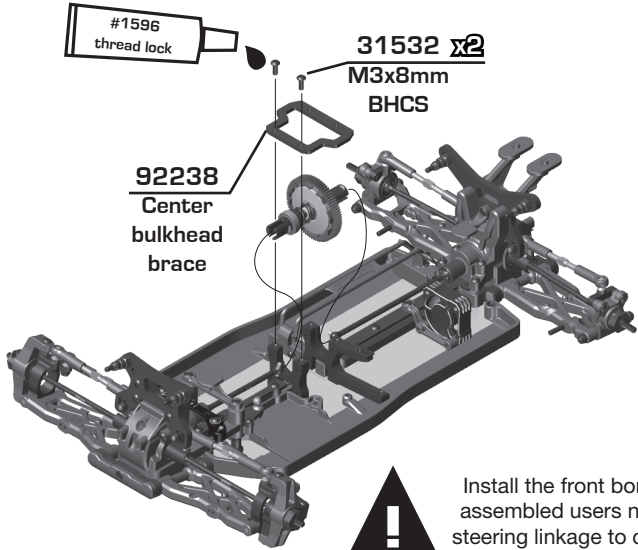
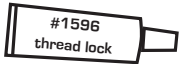

Install the front bone first. When assembled users need to shift the steering linkage to clear the ballcup



Upper fan mount optional. If not used, x2 M3x8mm BHCS are included for use on the top plate

25187 x2 M3x14mm BHCS
25211 x2 M3x10mm BHCS

Fan not included

92312 Fan mount, upper

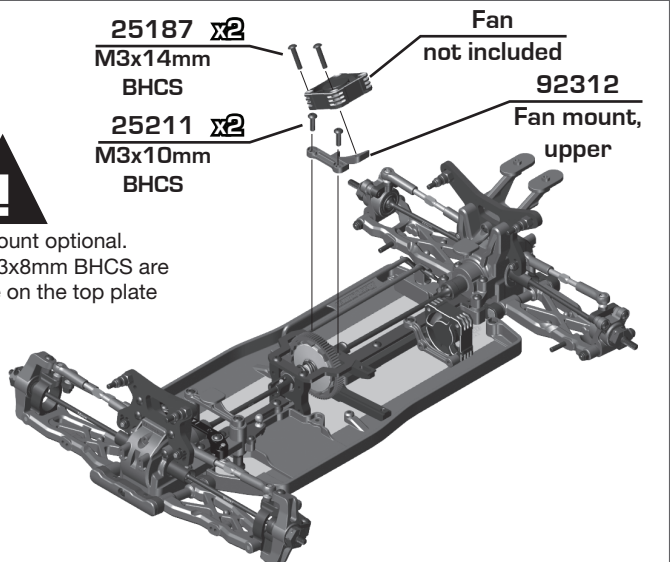

Bag 11 - Step 1

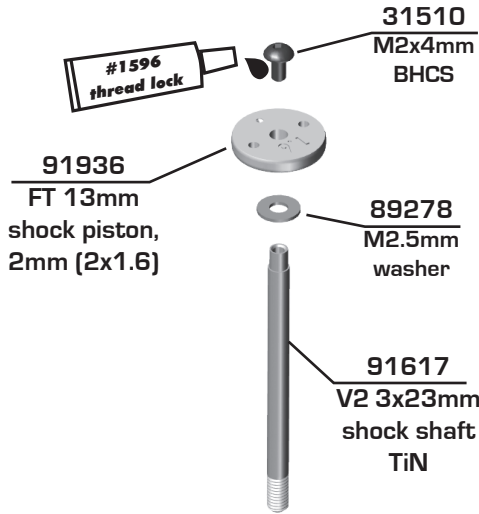

Build x2 front shocks

!
Mount the shock pistons with the number facing up!



Racers Tip:

Use a marker over the numbers on the pistons to make them easily visible!

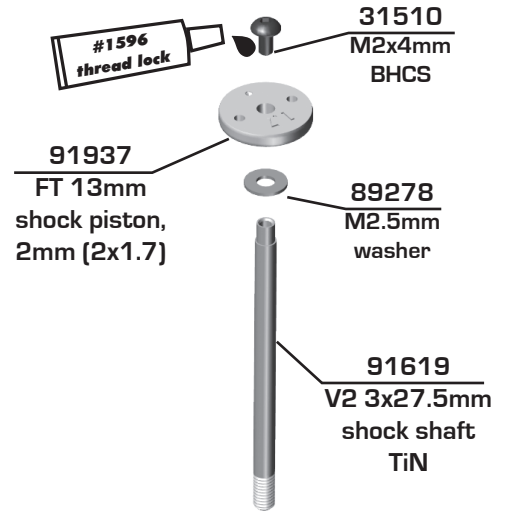

Build x2 rear shocks

Bag 11 - Step 2

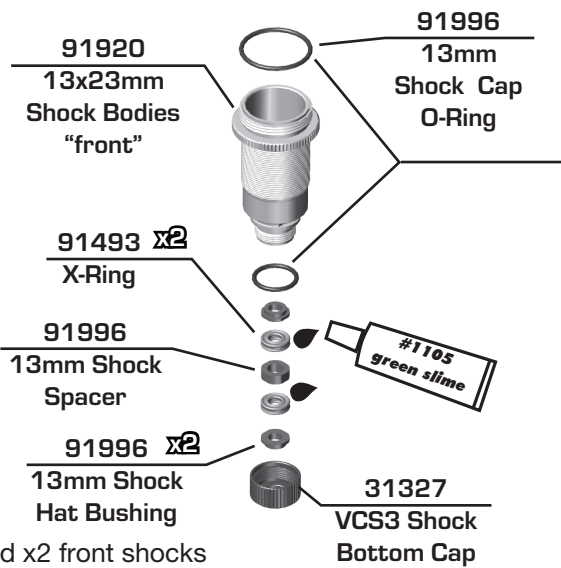

Build x2 front shocks

!
Lightly rub shock oil on the O-ring before installation!



Racers Tip:

Coating the X-rings with green slime (#1105) helps seal & reduce X-ring swell! Green slime not included in kit!

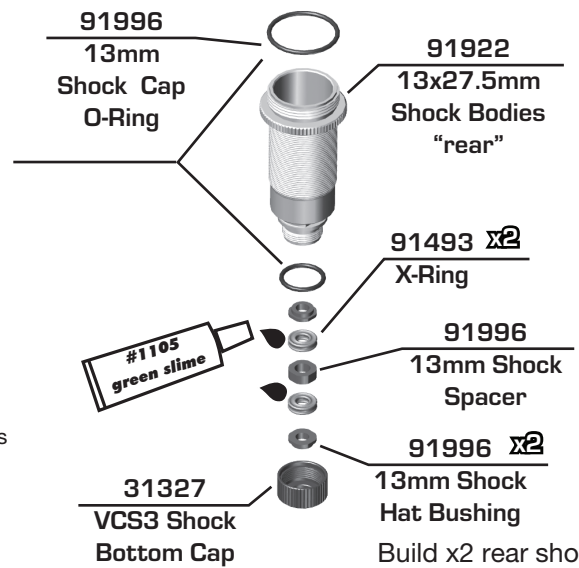

Build x2 rear shocks

Bag 11 - Step 3

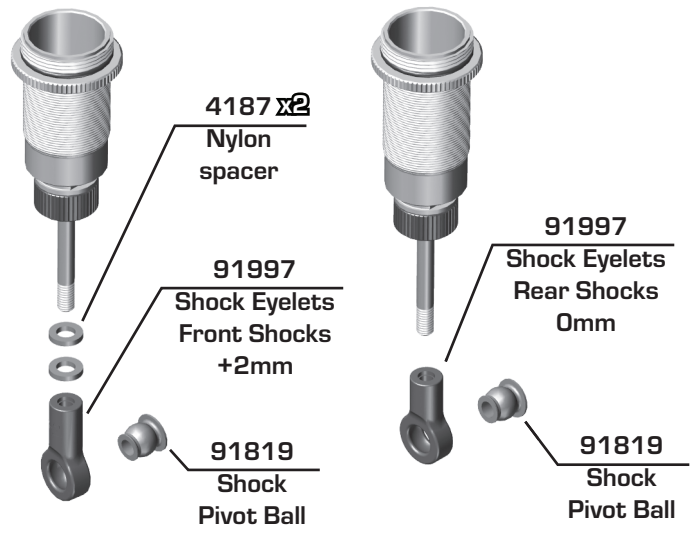
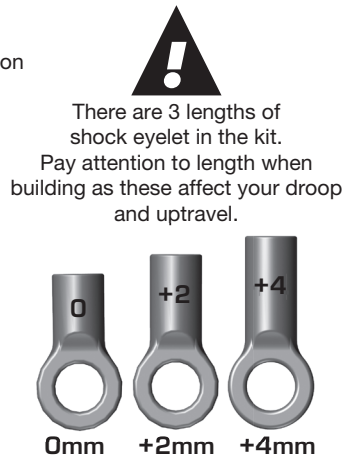
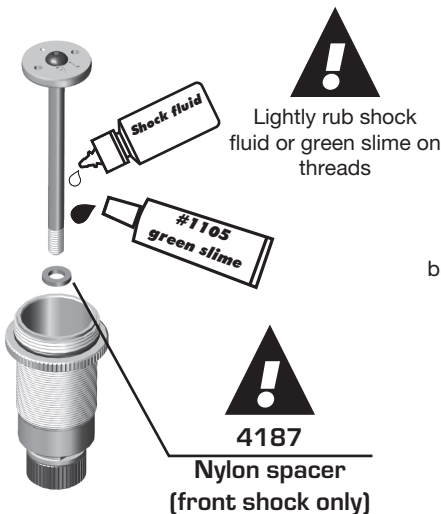

Build x2 front shocks

Build x2 rear shocks

:: Bag 11 - Step 4

Shock Fluids:
Front Shock: 45wt
Rear Shock: 35wt

Steps 2-3 **Steps 4-5** **Steps 6-7** **Step 8**

Shock Bleeding Steps:

1. Before assembly, get each bleed screw and thread it 1-2 turns into the shock cap, then remove the screw. This will make it easier when you are bleeding your shocks.
2. Pull shock shaft down.
3. Fill shock body 3/4 full with silicone shock fluid.
4. Slowly move the shock shaft up and down to remove air from under the piston.
5. Wait for bubbles to come to surface.
6. Fill shock body to top with silicone shock fluid.
7. Place a drop of oil in the cap and on cap threads.
8. Install cap (without bleed screw) and tighten completely.
9. Slowly compress shaft all the way to bleed excess silicone shock fluid out the hole in the cap (use rag around shock to catch excess fluid).
10. Install M2x4mm button head screw until snug while shaft is fully compressed.

91926
13mm Shock Cap

31510
2x4mm BHCS

Stroke
Front: 22mm
Rear: 27.5mm

Steps 9-10

:: Bag 11 - Step 5

91996 x4
13mm Threaded Collar O-ring

91928 x4
13mm Threaded Collar

91944
13mm Front Spring, Red (4.00lb)

91950
13mm Rear Spring, Blue (2.20lb)

Racers Tip:
Use your finger to rub shock fluid on the O-ring for smoother adjustment!

Build x4

:: Bag 11 - Step 6

Front: 7.5mm
Rear: 2.5mm

91926
13mm Shock Spring Cup "Front - 5mm"

Build x2 front shocks

#91926 13mm Shock Spring Cups

0mm 5mm 9mm

91926
13mm Shock Spring Cup "Rear - 0mm"

Build x2 rear shocks

! Hold shock mounting hardware until after anti-roll bar installation.

:: Bag 12 - Step 1

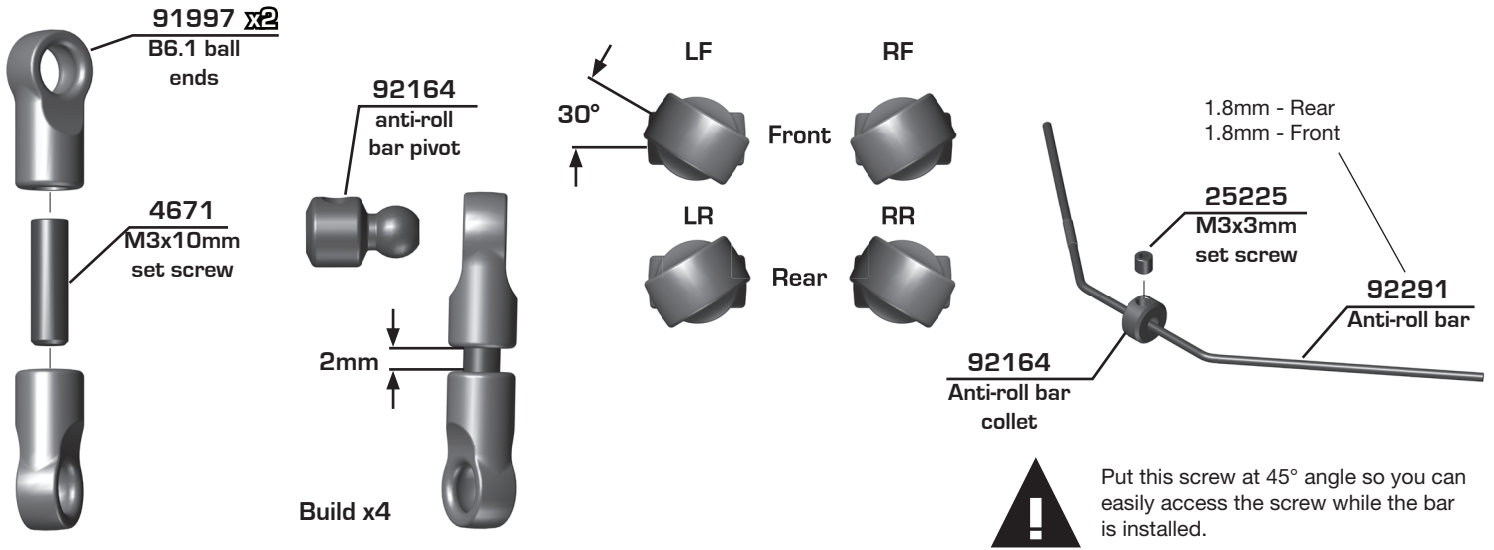

:: Bag 12 - Step 2

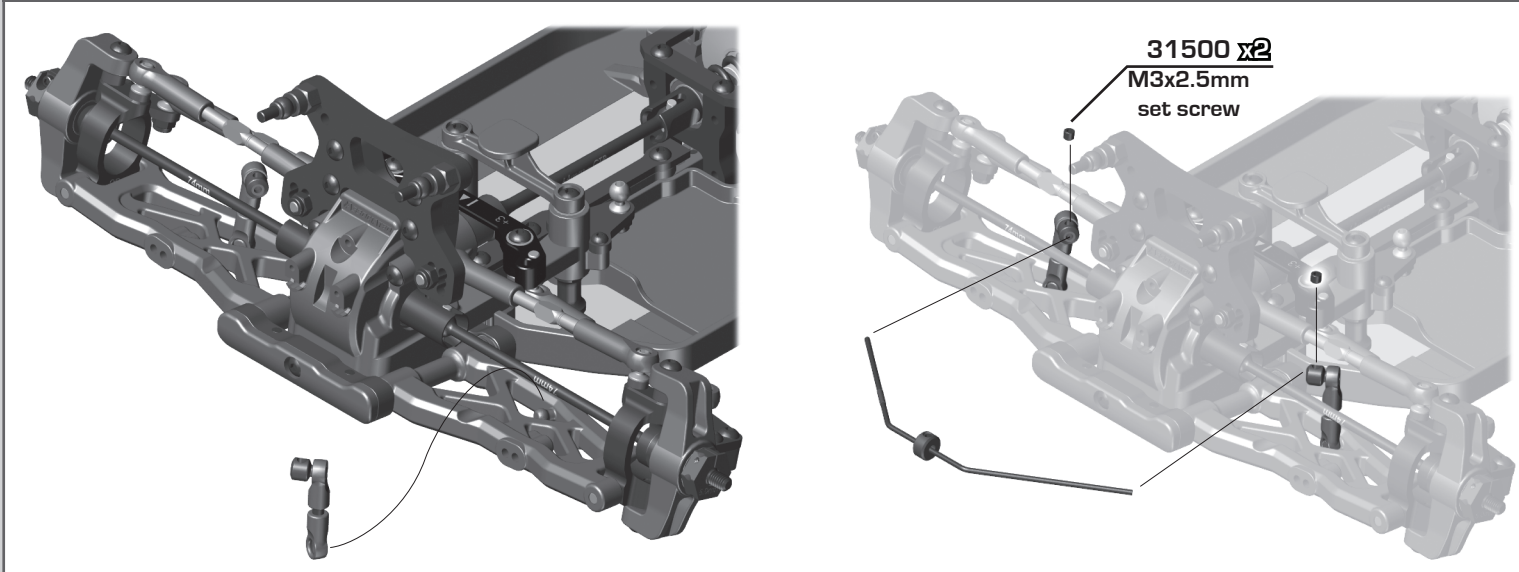

:: Bag 12 - Step 3

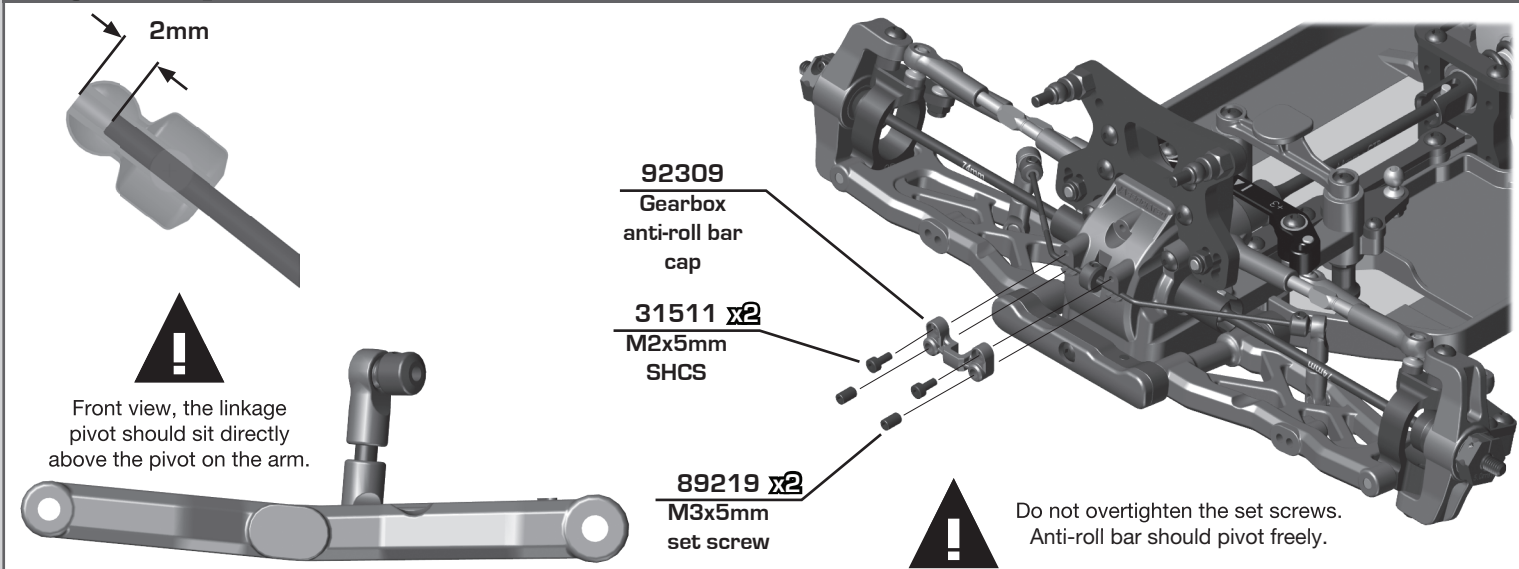

:: Bag 12 - Step 4

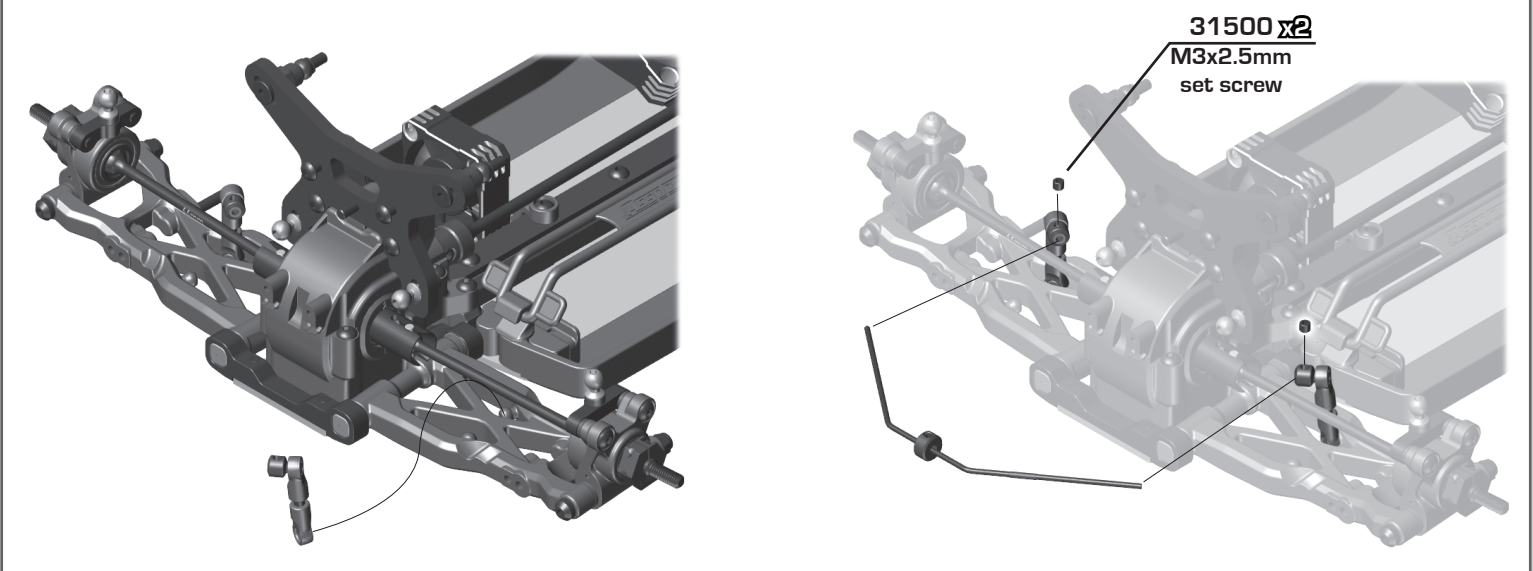

:: Bag 12 - Step 5

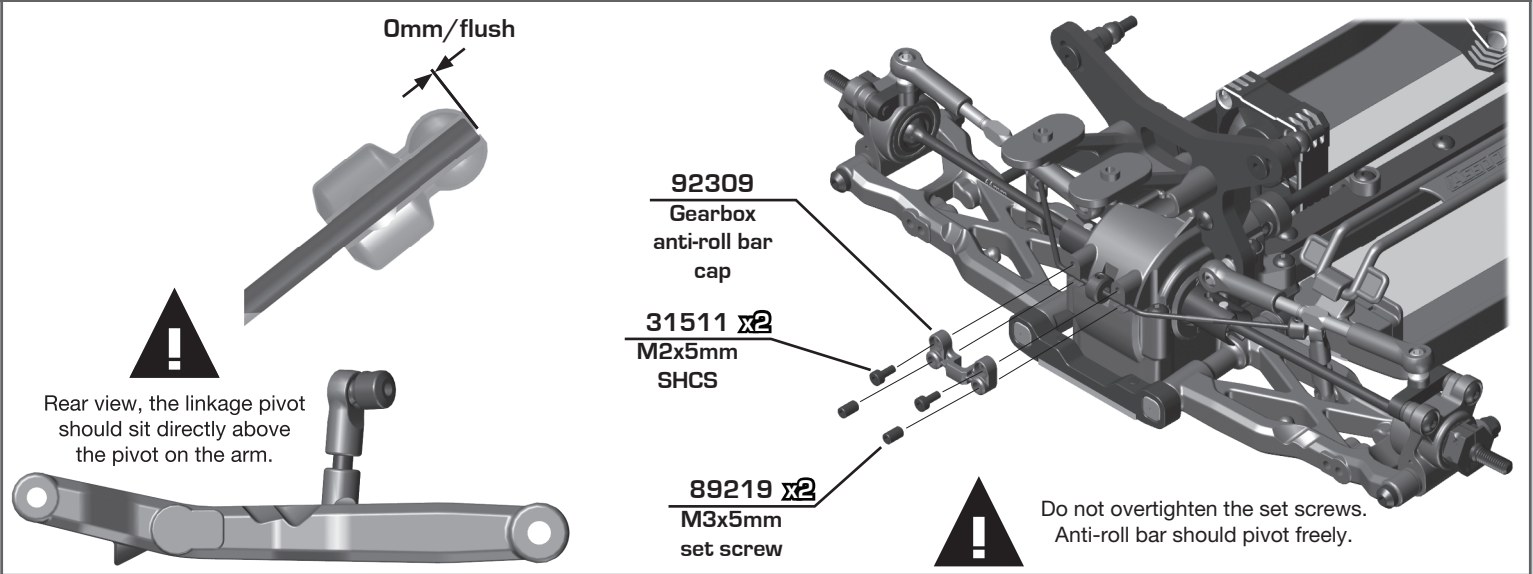

:: Bag 13 - Step 1

Install x2 front and x2 rear shocks

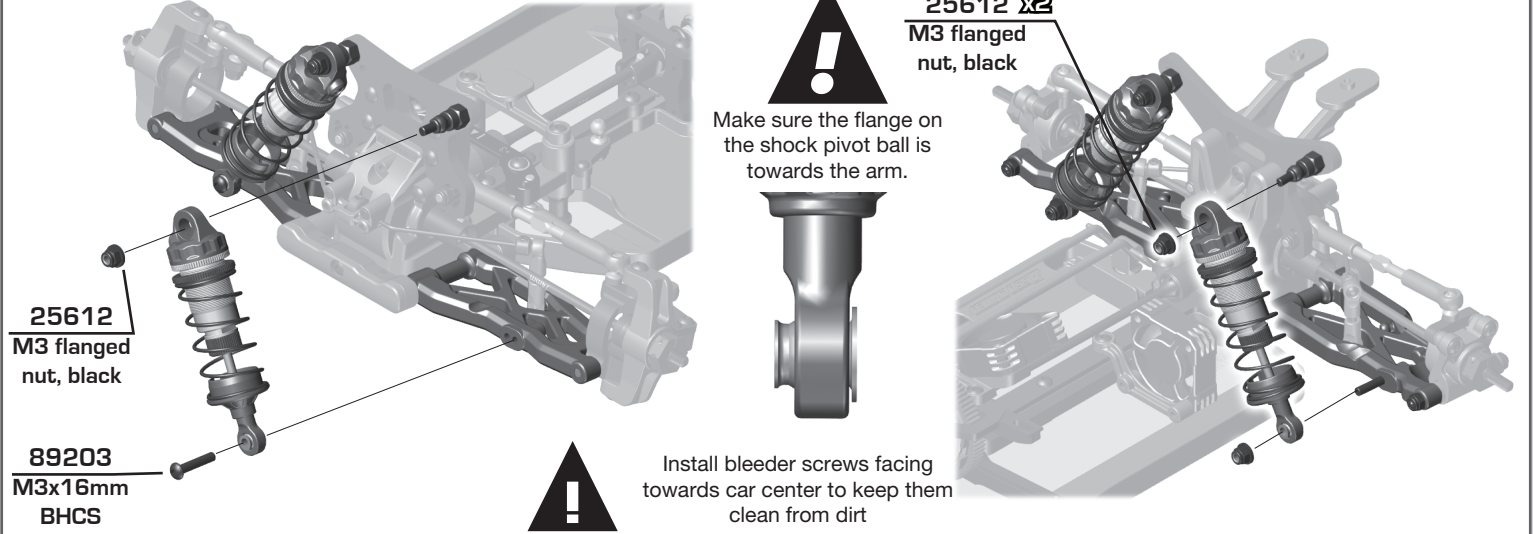

:: Bag 13 - Step 2

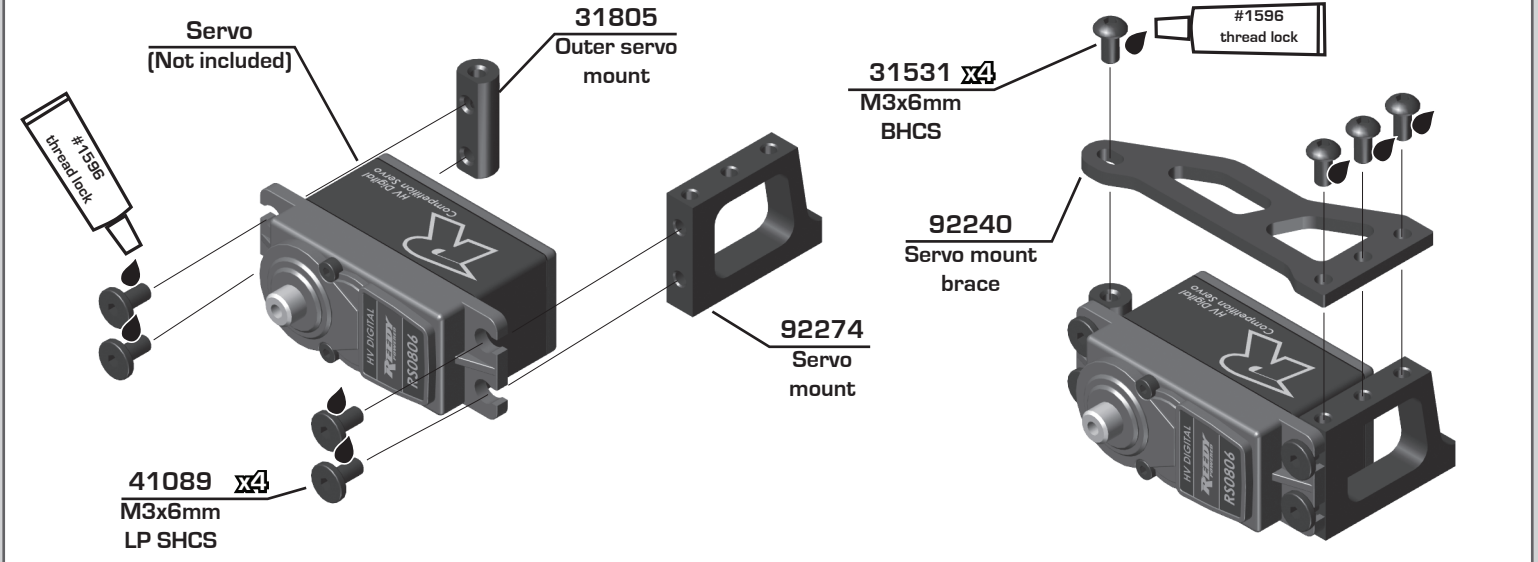

:: Bag 13 - Step 3

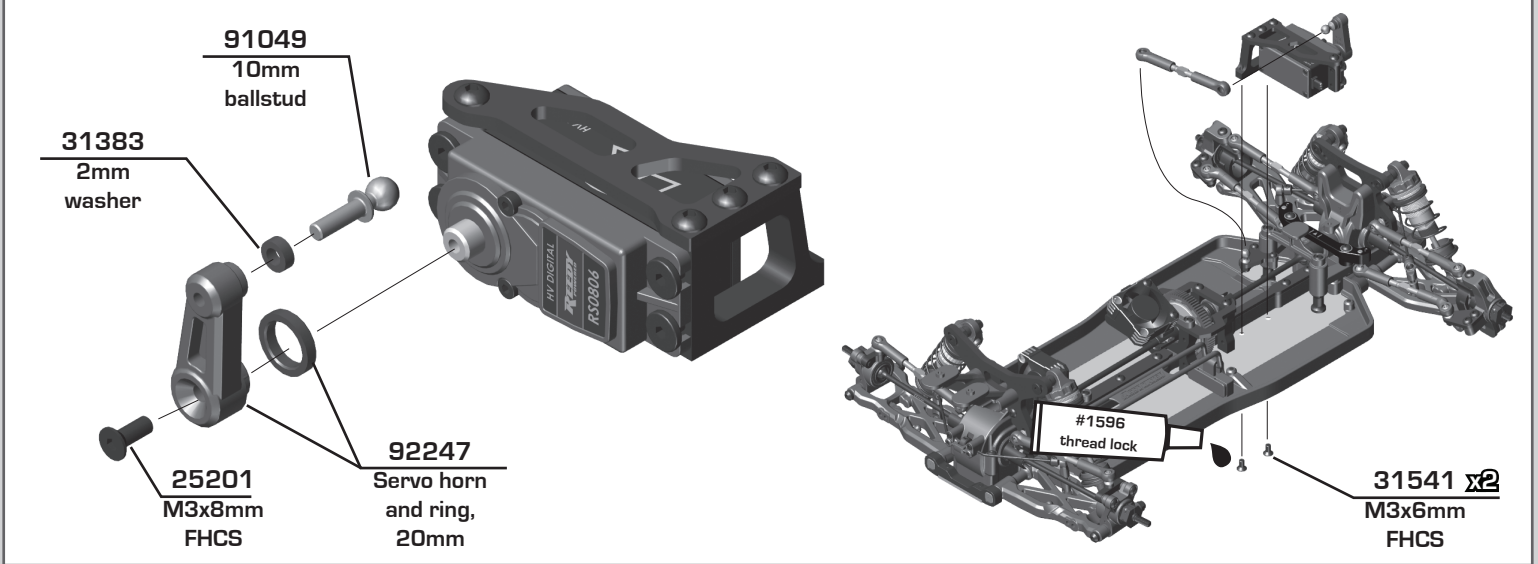

:: Bag 13 - Step 4

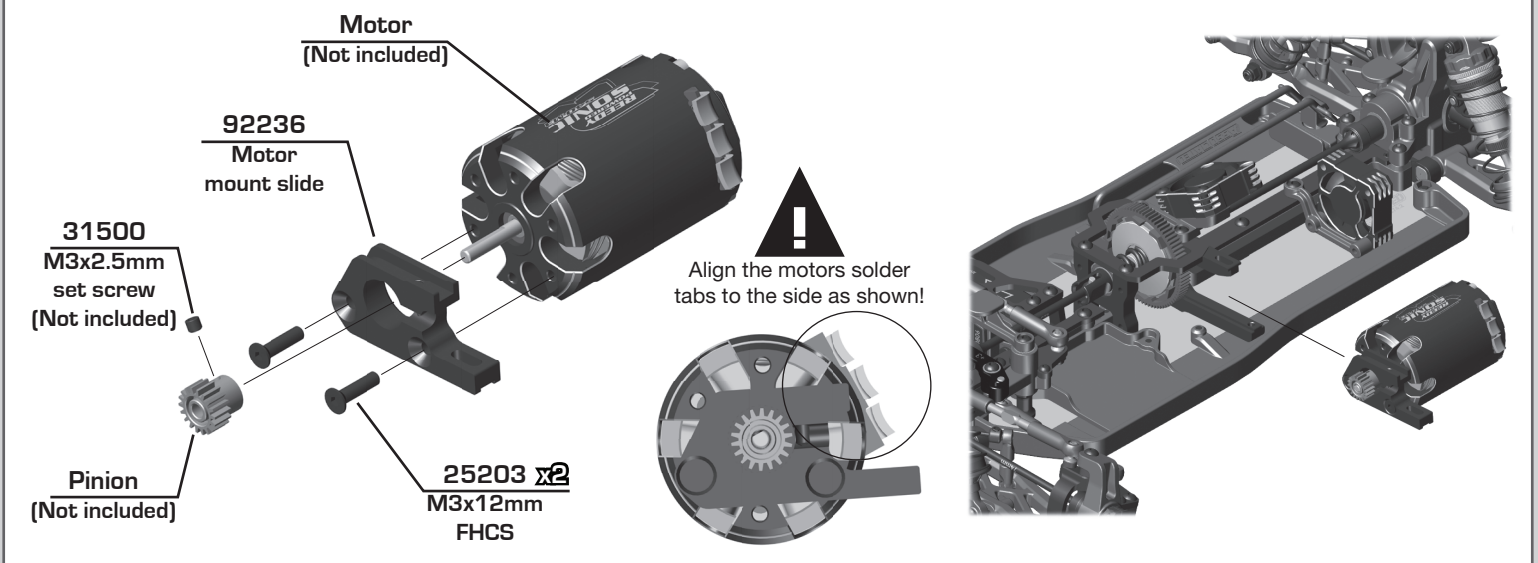

:: Bag 13 - Step 5

41090 x2
M3x10mm
LP SHCS

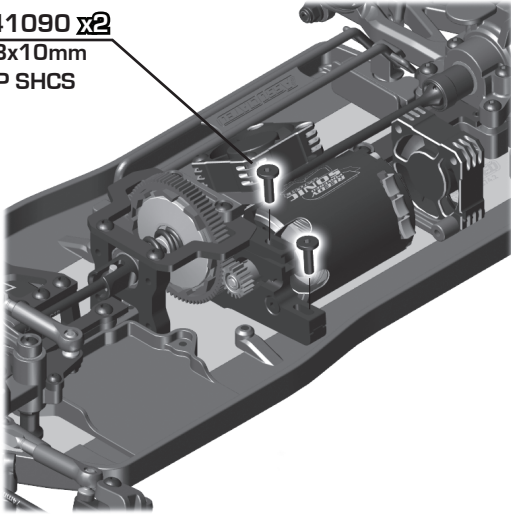

Receiver
(Not included)

ESC
(Not included)

6727 x2
Servo tape

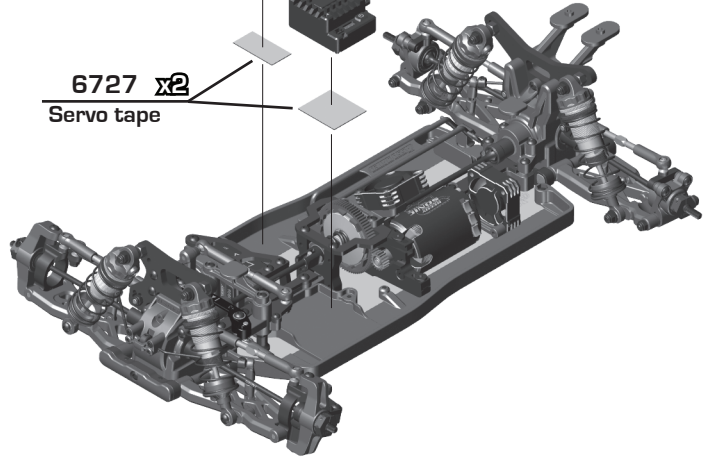

:: Bag 13 - Step 6

Battery
(Not included)

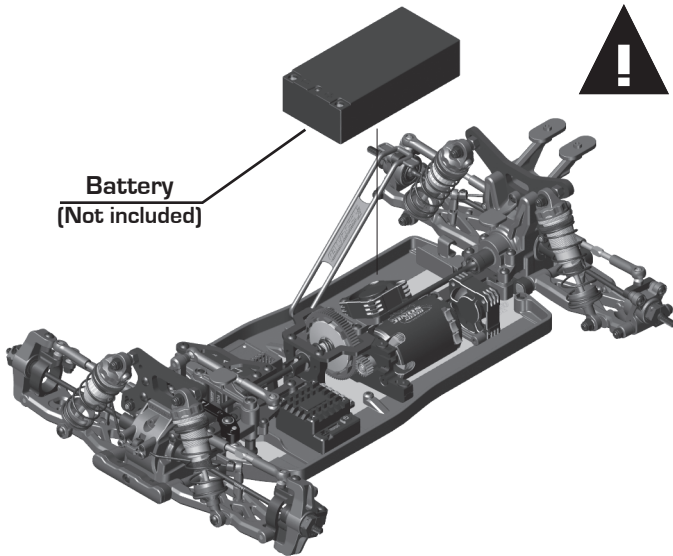

There are two cut line options on the rear wings.
The lower one is for carpet setup, the higher one
is for dirt setup.

Carpet
cut line

Dirt
cut line

91741
B6 wing

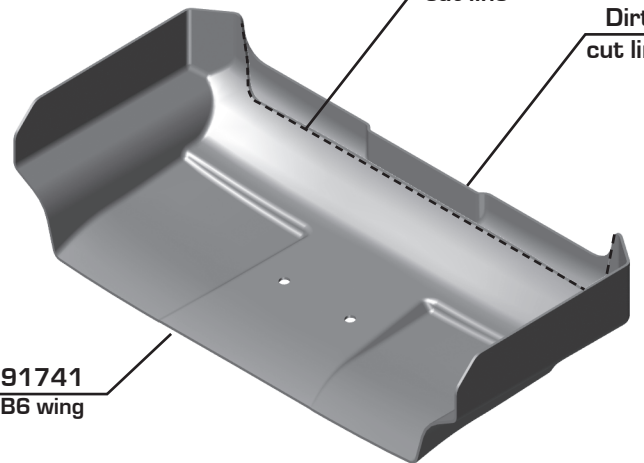

:: Bag 13 - Step 7

25202 x2
M3x10mm
FHCS

92312 x2
B74 wing
button

92312
B74 wing
angle shim

92251
B74 body
(light weight)

92252
B74 front
scoop

31520
M2.5x6mm
BHCS

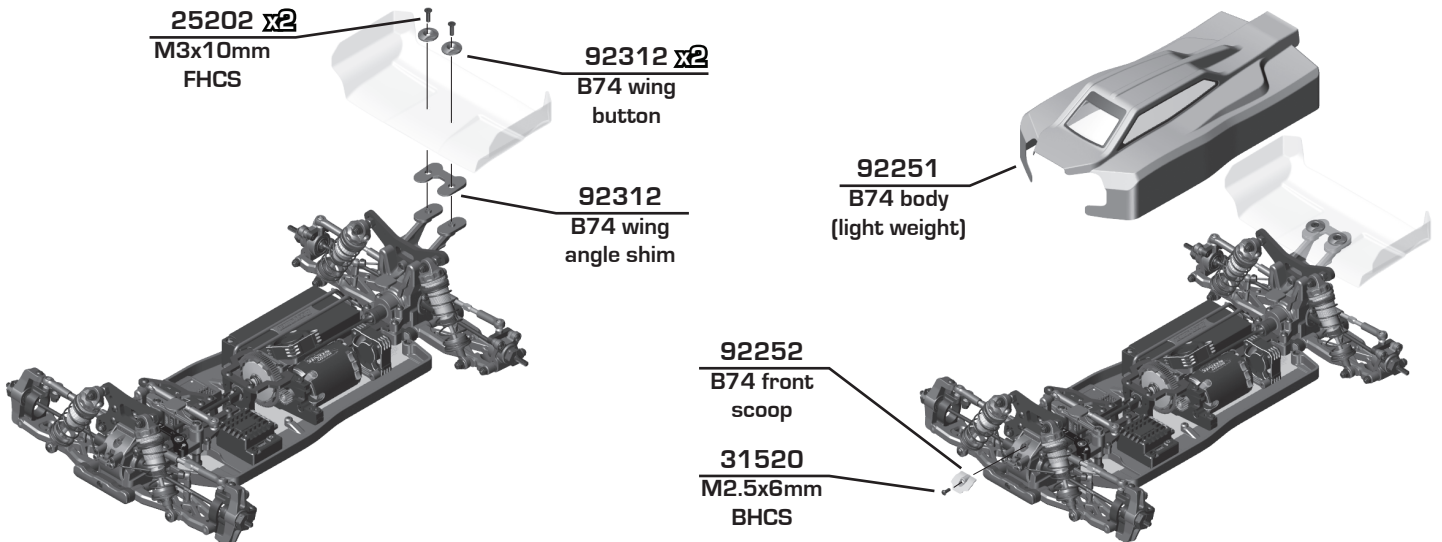

:: Bag 13 - Step 8



Trim the body using the pictures below as your guides.

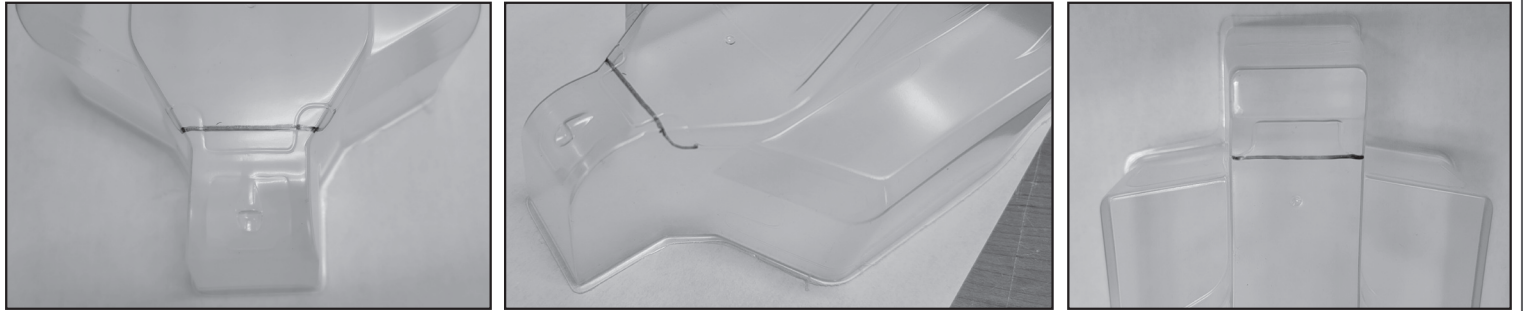

:: Bag 13 - Step 9

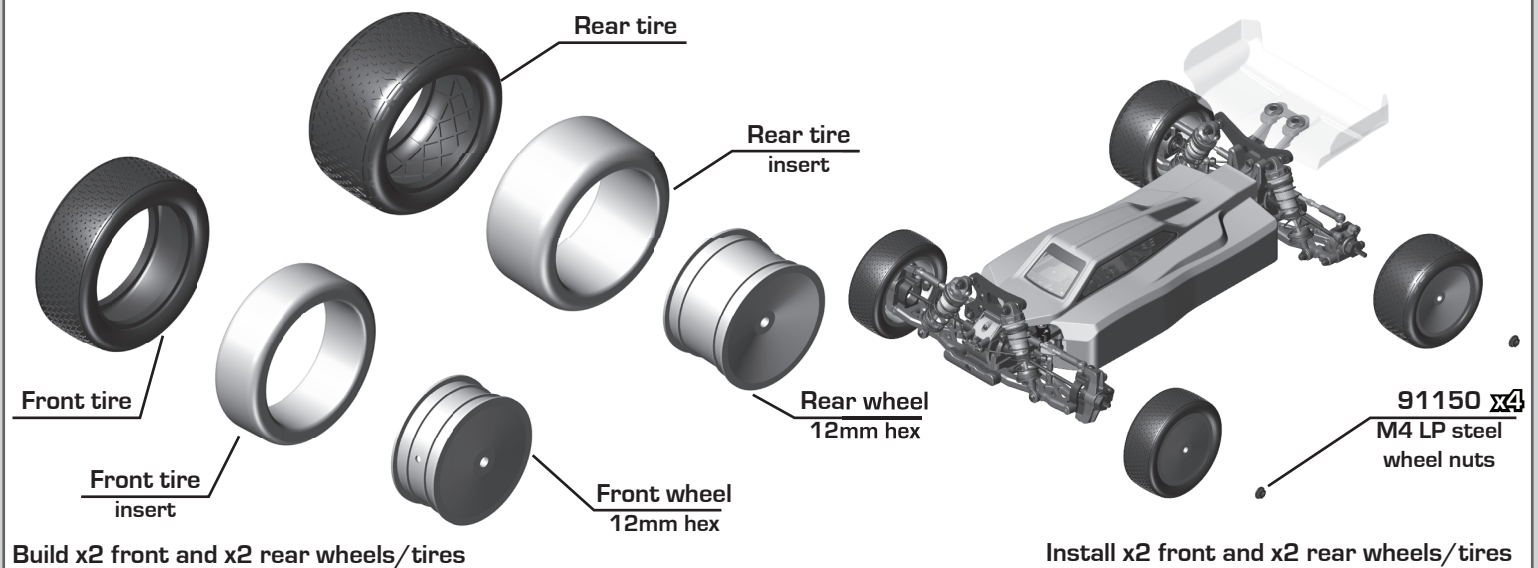

:: Tuning Tips - Painting, Beginners

Painting:

Your Kit requires a clear polycarbonate body. You will need to prep the body before you can paint it. Wash the **INSIDE** thoroughly with warm water and liquid detergent (do not use any detergents with scents or added hand lotion ingredients!). Dry the body using a clean, soft, lint-free cloth. Use the supplied window masks to cover the windows from the **INSIDE** of the body (RC bodies get painted on the inside). Using high quality masking tape, apply tape to the inside of the body to create a design. Spray (use either rattle can or airbrush) the paint on the inside of the body (preferably dark colors first, lighter colors last). **NOTE: ONLY** use paint that is recommended for (polycarbonate) plastics. If you do not, you can destroy the body! After the paint has completely dried (usually after 24 hours), cut the body along the trim lines. Make sure to drill or use a body reamer to make the holes for the antenna if needed! Use hook and loop tape to secure the body to the side rails of the vehicle.

Tips for Beginners:

Before making any changes to the standard setup, make sure you can get around the track without crashing. Changes to your vehicle will not be beneficial if you can't stay on the track. Your goal is consistent laps. Once you can get around the track consistently, start tuning your vehicle. Make only **ONE** adjustment at a time, testing it before making another change. If the result of your adjustment is a faster lap, mark the change on the included setup sheet (make additional copies of the sheet before writing on it). If your adjustment results in a slower lap, revert back to the previous setup and try another change. When you are satisfied with your vehicle, fill in the setup sheet thoroughly and file it away. Use this as a guide for future track days or conditions. Periodically check all moving suspension parts. Suspension components must be kept clean and move freely without binding to prevent poor and/or inconsistent handling.

:: Tuning Tips - Front Arm Mount Pill Insert Setups

Standard Position

Use this position as a reference when changing pill locations.

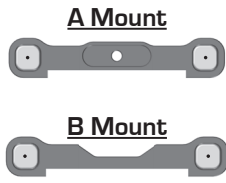

Kick-up: 8°
Roll Center: +0
Pin Width: +0

Possible Insert Locations

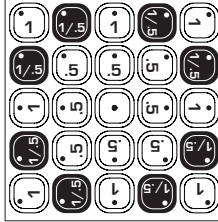

Insert Hole Locations

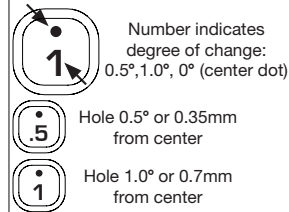

The aluminum front arm mounts utilize eccentric pill inserts to make fine adjustments to kick-up, pin height, and pin width. Adjustments can be made using the supplied inserts (#92014)

Pin Width
More distance = wider pivot
Less distance = narrower pivot

A Mount	B Mount	
		= +1.4mm
		= +0.7mm
		= 0mm
		= -0.7mm
		= -1.4mm

Pin Height
Higher pin = Higher roll center
Lower Pin = Lower roll center

A Mount	B Mount	
		= +0.7mm
		= +0.35mm
		= 0mm
		= -0.35mm
		= -0.7mm

Kick Up

More angle = More kick up
Less angle = Less kick up

A Mount	B Mount	
		= 8°
		= 7°
		= 6°
		= 9°
		= 8°
		= 7°
		= 10°
		= 9°
		= 8°

Total Caster Angle

Total caster angle is the sum of the kick up angle and the caster block angle.

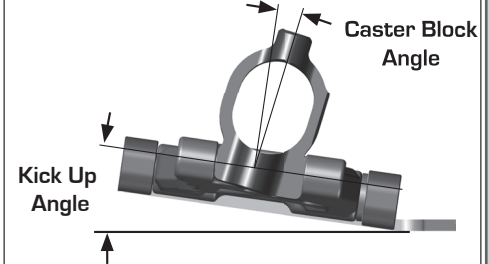

Caster Block Angle	Kick Up Angle				
	6°	7°	8°	9°	10°
8°	14°	15°	16°	17°	18°
9°	15°	16°	17°	18°	19°
10°	16°	17°	18°	19°	20°

:: Tuning Tips - Rear Arm Mount Pill Insert Setups

Standard Position

Use this position as a reference when changing pill locations.

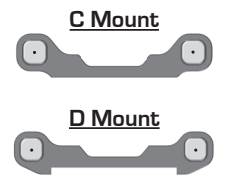

Toe: 3°
Anti-Squat: 2°
Roll Center: +0
Pin Width: +0

Possible Insert Locations

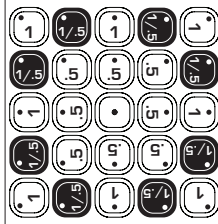

Insert Hole Locations

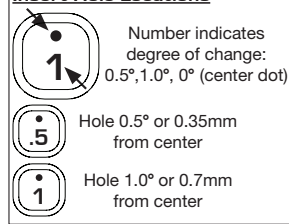

The aluminum front arm mounts utilize eccentric pill inserts to make fine adjustments to kick-up, pin height, and pin width. Adjustments can be made using the supplied inserts (#92014)

Pin Width
More distance = wider pivot
Less distance = narrower pivot

C Mount	D Mount	
		= +1.4mm
		= +0.7mm
		= 0mm
		= -0.7mm
		= -1.4mm

Pin Height
Higher pin = Higher roll center
Lower Pin = Lower roll center

C Mount	D Mount	
		= +0.7mm
		= +0.35mm
		= 0mm
		= -0.35mm
		= -0.7mm

Anti-Squat Angle

More angle = More anti-squat
Less angle = Less anti-squat

C Mount	D Mount	
		= 2°
		= 1°
		= 0°
		= 3°
		= 2°
		= 1°
		= 4°
		= 3°
		= 2°

Toe Angle

More angle = More toe in
Less angle = Less toe in
Shown in 1° changes

C Mount	D Mount	
		= 3°
		= 4°
		= 5°
		= 2°
		= 3°
		= 4°
		= 1°
		= 2°
		= 3°

Front Suspension:

Ride Height:	13mm
Camber:	-1deg
Toe:	1deg
Anti-Roll Bar:	1.8mm
Arm Type:	Gull Wing - Standard
Tower Type:	Gull Wing
Wheelbase Shim:	1mm behind arm
Wheel Hex:	5.0mm
Caster Block:	8° <input type="checkbox"/> 9° <input checked="" type="checkbox"/> 10° <input type="checkbox"/>
Chassis Brace Support:	2mm G10
Top Plate Brace:	None
Front Axles:	CVA <input checked="" type="checkbox"/> DCV <input type="checkbox"/>
Notes:	

1 2

Front Chassis Brace Screws: _____ Ball Stud Spacing: 1mm

Arm Mount A: 1° 0.5°
 Gray Black

Arm Mount B: 1° 0.5°
 Gray Black

Diff Height: +2 +0

Axle Height: +3 +2 +1 0

Ball Stud Spacing: 0mm

Steering Plate: Kit - "0"

Ball Stud Spacing: 2mm

74mm

B A

Rear Suspension:

Ride Height:	13mm
Camber:	-1deg
Anti-Roll Bar:	1.8mm
Arm Type:	Standard
Wheelbase Shim:	2mm in front of arm
Wheel Hex:	6.0mm
Chassis Brace Support:	2mm G10
Hub Spacing:	Fwd <input type="checkbox"/> Mid <input checked="" type="checkbox"/> Back <input type="checkbox"/>
Notes:	

Rear Chassis Brace Screws: _____

Arm Mount C: 1° 0.5°
 Gray Black

Arm Mount D: 1° 0.5°
 Gray Black

Diff Height: +3 +2 +1 +0

Axle Height: 0 3 +3
 1 2 +2
 1 2 +1
 0 3 +0

Camber Link Spacing: 1mm

Ball Stud Spacing: 2mm

66mm

C B A

Electronics:

Radio:	Servo:
EPA: Throttle: %	Brake: %
ESC:	
ESC Settings:	
Motor / Wind:	Timing:
Pinion:	Spur: 78T
Battery:	
Battery Position:	
Back 1 <input type="checkbox"/> 2 <input type="checkbox"/> 3 <input type="checkbox"/> 4 <input checked="" type="checkbox"/> Forward	
Battery Weight:	

Differential:

	Front	Center	Rear
Fluid:	15K		15K
Gears:	Metal		Metal
Type:	LTC		LTC
Notes:			
Slipper Clutch:			
Type:	Octalock 11mm LCF		
# of Pads:	2 Pad		
Setting:	2.1mm		

Shocks:

	Front	Rear
Piston:	2x1.6	2x1.7
Thickness:	2mm	2mm
Fluid:	45wt	35wt
Spring:	Red	Blue
Limiters:	Int: 1 Ext: 2	Int: ___ Ext: ___
Stroke:	22mm	27.5mm
Eyelet Length:	+2	0
Cup Offset:	5mm	0mm
Notes:		



Track Info:

Size:	Small <input type="checkbox"/> Medium <input type="checkbox"/> Large <input type="checkbox"/> Extra Large <input type="checkbox"/>
Surface:	Dirt <input type="checkbox"/> Carpet <input type="checkbox"/> AstroTurf <input type="checkbox"/> Multi Surface <input type="checkbox"/>
Traction:	Low <input type="checkbox"/> Medium <input type="checkbox"/> High <input type="checkbox"/> Very High <input type="checkbox"/>
Moisture:	Dry <input type="checkbox"/> Damp <input type="checkbox"/> Wet <input type="checkbox"/>
Condition:	Indoor <input type="checkbox"/> Outdoor <input type="checkbox"/> Dusty <input type="checkbox"/> Hard Packed <input type="checkbox"/> Bumpy <input type="checkbox"/> Grooved <input type="checkbox"/> Smooth <input type="checkbox"/> Loamy <input type="checkbox"/>
Temperature:	Ambient: _____ Track: _____
Notes:	
Vehicle Comments:	

Tires:



Front Tires:	
Front Compound:	
Front Insert:	
Rear Tires:	
Rear Compound:	
Rear Insert:	
Wheel (F/R):	
Notes:	

Body, Wing, Weight:

Body:	Kit - Lightweight
Front Wing:	Yes <input type="checkbox"/> No <input checked="" type="checkbox"/>
Rear Wing:	Kit
Wing Angle:	0° <input type="checkbox"/> 6° <input checked="" type="checkbox"/>
Wing Mount Height:	0 <input type="checkbox"/> -2 <input checked="" type="checkbox"/>
Servo Weights:	
Electronic Weights:	
Total Vehicle Weight:	

Front Suspension:

Ride Height: _____
 Camber: _____
 Toe: _____
 Anti-Roll Bar: _____
 Arm Type: _____
 Tower Type: _____
 Wheelbase Shim: _____
 Wheel Hex: _____
 Caster Block: 8° 9° 10°
 Chassis Brace Support: _____
 Top Plate Brace: _____
 Front Axles: CVA DCV
 Notes: _____

1 
 2 
 Front Chassis Brace Screws: _____
 Arm Mount A: 1° 0.5°
 Gray Black
 Arm Mount B: 1° 0.5°
 Gray Black

Ball Stud Spacing: _____
 Diff Height: +2
 +0

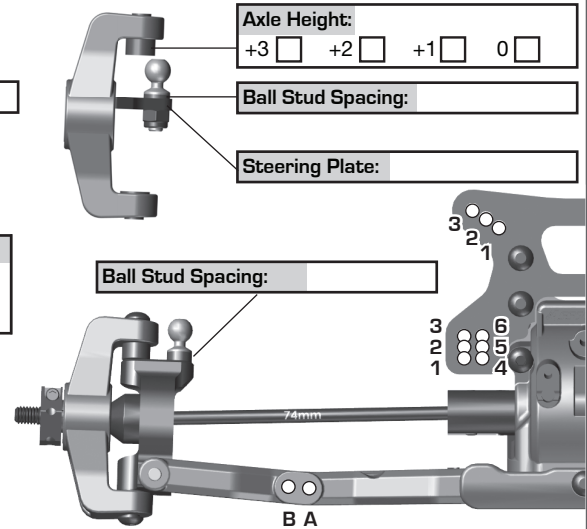
Axle Height: +3 +2 +1 0
 Ball Stud Spacing: _____
 Steering Plate: _____
 Ball Stud Spacing: _____

Rear Suspension:

Ride Height: _____
 Camber: _____
 Anti-Roll Bar: _____
 Arm Type: _____
 Wheelbase Shim: _____
 Wheel Hex: _____
 Chassis Brace Support: _____
 Hub Spacing: Fwd Mid Back
 Notes: _____

Rear Chassis Brace Screws: _____
 Arm Mount C: 1° 0.5°
 Gray Black
 Arm Mount D: 1° 0.5°
 Gray Black

Diff Height: +3
 +2
 +1
 +0

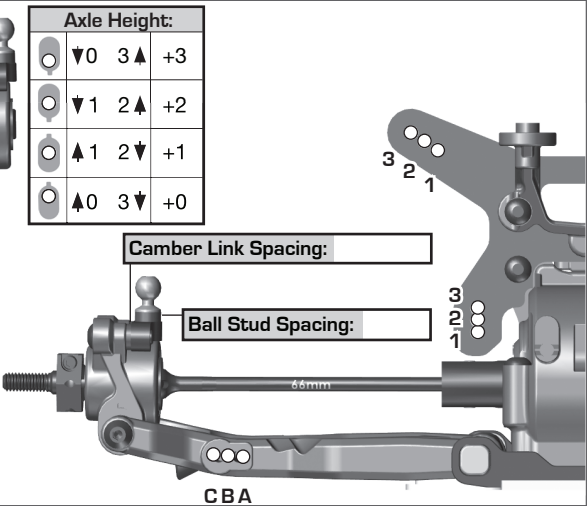
Axle Height: 0 3A +3
 1 2A +2
 1 2V +1
 0 3V +0
 Camber Link Spacing: _____
 Ball Stud Spacing: _____

Electronics:

Radio: _____ Servo: _____
 EPA: Throttle: _____ % Brake: _____ %
 ESC: _____
 ESC Settings: _____
 Motor / Wind: _____ Timing: _____
 Pinion: _____ Spur: _____
 Battery: _____
 Battery Position: Back 1 2 3 4 Forward
 Battery Weight: _____

Differential:

	Front	Center	Rear
Fluid:			
Gears:			
Type:			
Notes:	_____		

Slipper Clutch: Type: _____
 # of Pads: _____
 Setting: _____

Shocks:

	Front	Rear
Piston:		
Thickness:		
Fluid:		
Spring:		
Limiters:	Int: _____ Ext: _____	Int: _____ Ext: _____
Stroke:		
Eyelet Length:		
Cup Offset:		
Notes:	_____	

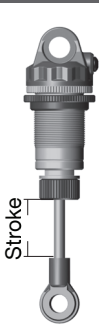

Track Info:

Size: Small Medium Large Extra Large
 Surface: Dirt Carpet Astroturf Multi Surface
 Traction: Low Medium High Very High
 Moisture: Dry Damp Wet
 Condition: Indoor Outdoor Dusty Hard Packed
 Bumpy Grooved Smooth Loamy
 Temperature: Ambient: _____ Track: _____
 Notes: _____
 Vehicle Comments: _____

Tires:

Front Tires: _____
 Front Compound: _____
 Front Insert: _____
 Rear Tires: _____
 Rear Compound: _____
 Rear Insert: _____
 Wheel (F/R): _____
 Notes: _____

Body, Wing, Weight:

Body: _____
 Front Wing: Yes No
 Rear Wing: _____
 Wing Angle: 0° 6°
 Wing Mount Height: 0 -2
 Servo Weights: _____
 Electronic Weights: _____
 Total Vehicle Weight: _____

FIND IT ON ASSOCIATEDELECTRICS.COM

CARS & TRUCKS



Vehicle Spare Parts GO TO:

AssociatedElectrics.com →
Team Associated tab →
Cars & Trucks →
Scroll to your vehicle →
Parts & Accessories link

SETUP SHEETS & MANUALS



Setups and Manuals GO TO:

AssociatedElectrics.com →
Team Associated tab →
Manuals & Setups →
Scroll to your vehicle

A-TEAM APPS



Tuning Guides & Tips GO TO:

AssociatedElectrics.com →
Support →
A-Team Apps

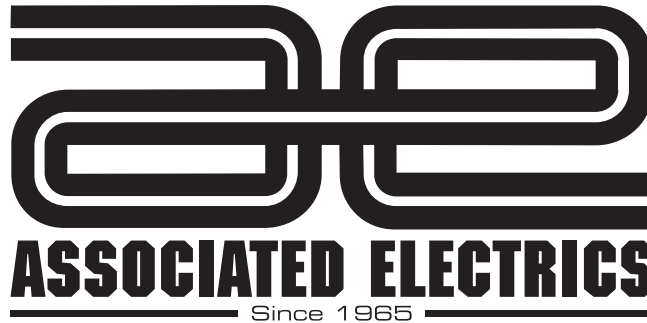

Associated Electrics, Inc.
21062 Bake Parkway Lake Forest, CA 92630 USA

call: (949) 544-7500 - fax: (949) 544-7501
Check out the following web sites for all of our kits, current products,
new releases, setup help, tips, and racing info!
www.AssociatedElectrics.com

FOLLOW US ON SOCIAL MEDIA



TeamAssociated
ReedyPower
ElementRC



@TeamAssociatedRC
@ReedyPower
@Element_RC



@Team_Associated
@ReedyPower